



# A Celebration of Fifty Years of Satellite Laser Ranging

**Dr. John J. Degnan, Chief Scientist**

**Sigma Space Corporation, Lanham, MD 20706 USA**

**(retired from NASA Goddard Space Flight Center in 2003)**

**Joint Science/Engineering Colloquium**

**19<sup>th</sup> International Workshop on Laser Ranging**

**Goddard Space Flight Center, Greenbelt, MD, USA**

**October 29, 2014**



# OVERVIEW



- First GSFC SLR Experiment on October 31, 1964
- SLR Technology and Science Highlights by Decade
- Precise Orbit Determination (POD) support for Remote Sensing Missions
- Laser Time Transfer and Relativity
- Interplanetary Laser Transponders and Communications
- Laser Altimetry and 3D Imaging Lidars (time permitting)
- Summary Slide



# Space Geodetic Techniques



## Satellite Laser Ranging



## Very Long Baseline Interferometry

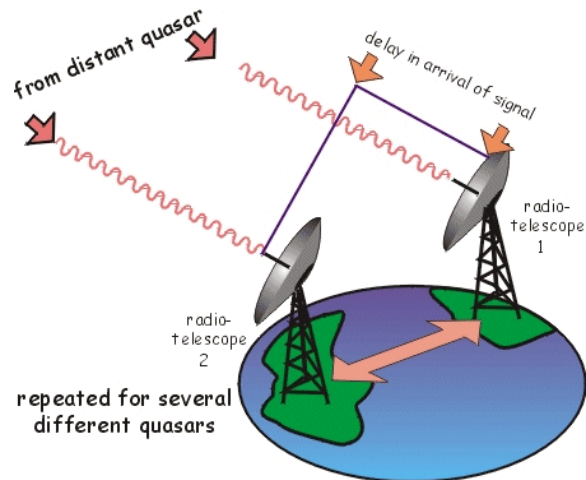

**Global Navigation Satellite Systems (GNSS)**  
GPS(USA), GLONASS (Russia), Galileo (ESA)

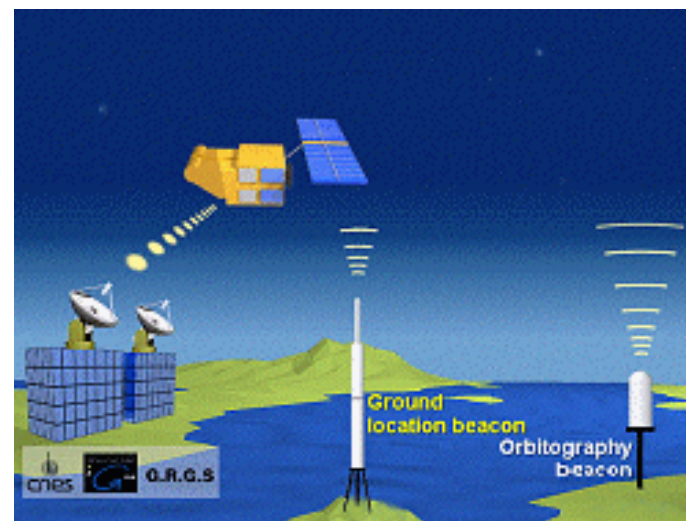

**DORIS (Doppler Orbitography and Radiopositioning Integrated by Satellite)**



## SATELLITE LASER RANGING - 1964

### GODdard LASer (GODLAS)

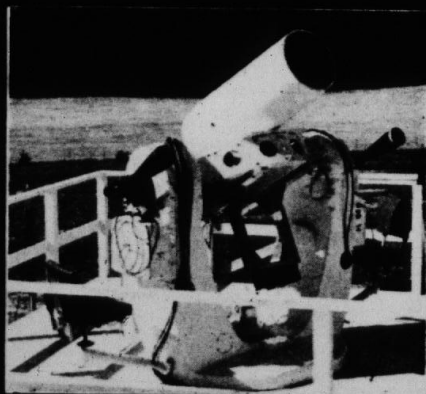

TRANSMITTING LASER AND RECEIVING TELESCOPE, MOUNTED ON A MODIFIED NIKE-AJAX RADAR PEDESTAL.

### Code 524 SLR Team

Dr. Henry H. Plotkin

**Thomas S. Johnson\***

Paul L. Spadin

John E. Moye

**Walter J. Carrion\***

**Nelson McAvoy\***

**Sol Howard Genatt\***

Louis O. Caudill

Peter O. Minott

Herbert L. Richards

Michael W. Fitzmaurice

John J. Degnan

Ed Reid

Charles J. Peruso

**Hal Walker**

**\* Deceased**

### BE-B: first satellite with retro-reflectors

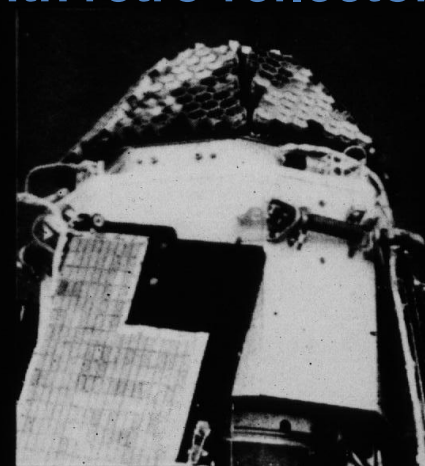

THE BEACON EXPLORER-B SATELLITE WITH ARRAY OF CUBE-CORNER REFLECTORS.

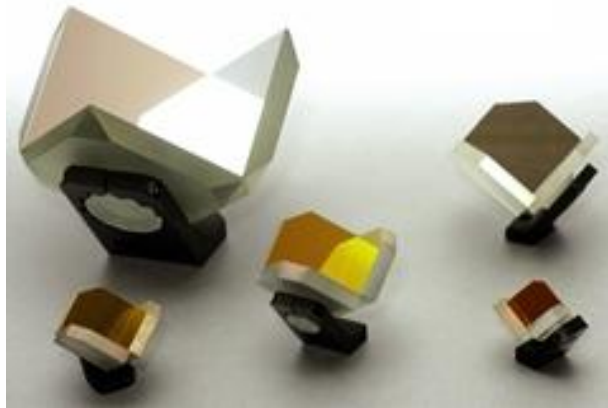
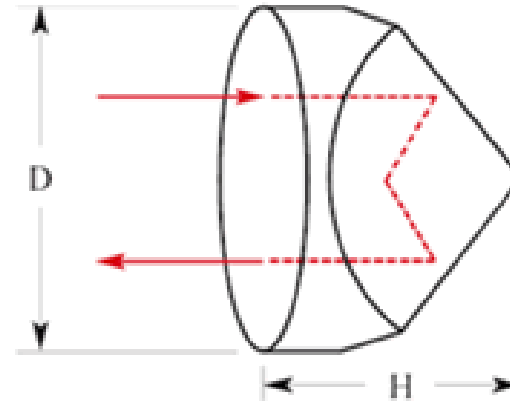
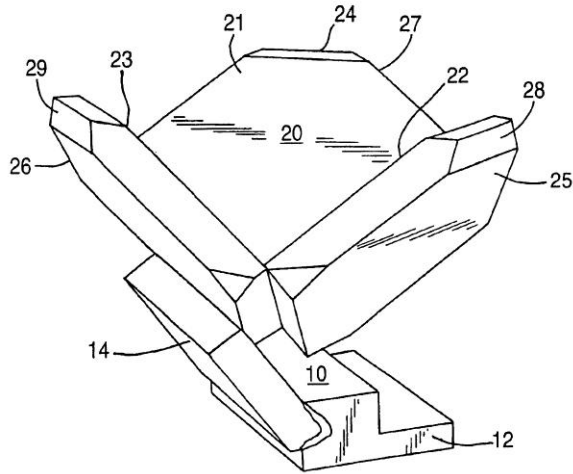

**Hollow Cube Corner**

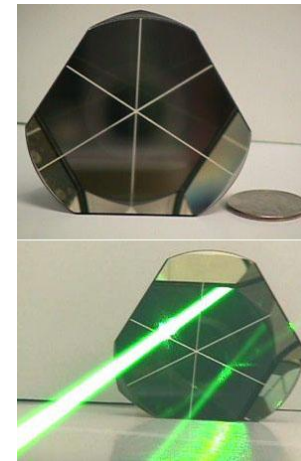

**Solid Cube Corner**

Cube corner retroreflectors reflect light back to the point of origin in a narrow beam while increasing the number of reflectors increases the return signal strength.



# Peak Cross-Section of a Perfect Cube Corner



For normally incident light, a single unspoiled retroreflector (cube corner) has a peak, on-axis, optical cross-section defined by

$$\sigma_{cc} = \rho A_{cc} \left( \frac{4\pi}{\Omega} \right) = \rho \left( \frac{4\pi A_{cc}^2}{\lambda^2} \right) = \frac{\pi^3 \rho D^4}{4\lambda^2}$$

where the reflectivity of the cube corner,  $\rho$ , is typically equal to 0.78 or 0.93 for aluminum-coated back faces and uncoated Total Internal Reflection (TIR) surfaces respectively,  $A_{cc}$  is the collecting aperture of the corner cube,  $D$  is the cube diameter, and  $4\pi/\Omega$  is the on-axis reflector gain and  $\Omega$  is the effective solid angle occupied by the Far Field Diffraction Pattern (FFDP) of the retroreflector.

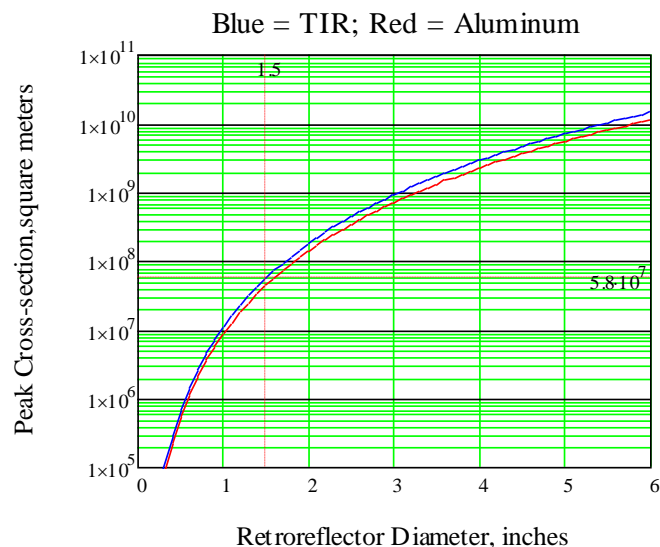

The peak optical cross-section rises rapidly as the retroreflector diameter to the fourth power. For the popular 1.5 in (38 mm) diameter cube with a physical cross-section of 0.001m<sup>2</sup>, the peak optical cross-section is about 5.8 x 10<sup>7</sup> m<sup>2</sup>, an increase of over ten orders of magnitude.





# Goddard News, Nov. 30, 1964



**Dr. Henry H. Plotkin**  
Branch Head  
Physicist

**Walter J. Carrion (Dec)**  
Asst. Branch Head  
Mechanical Engineer

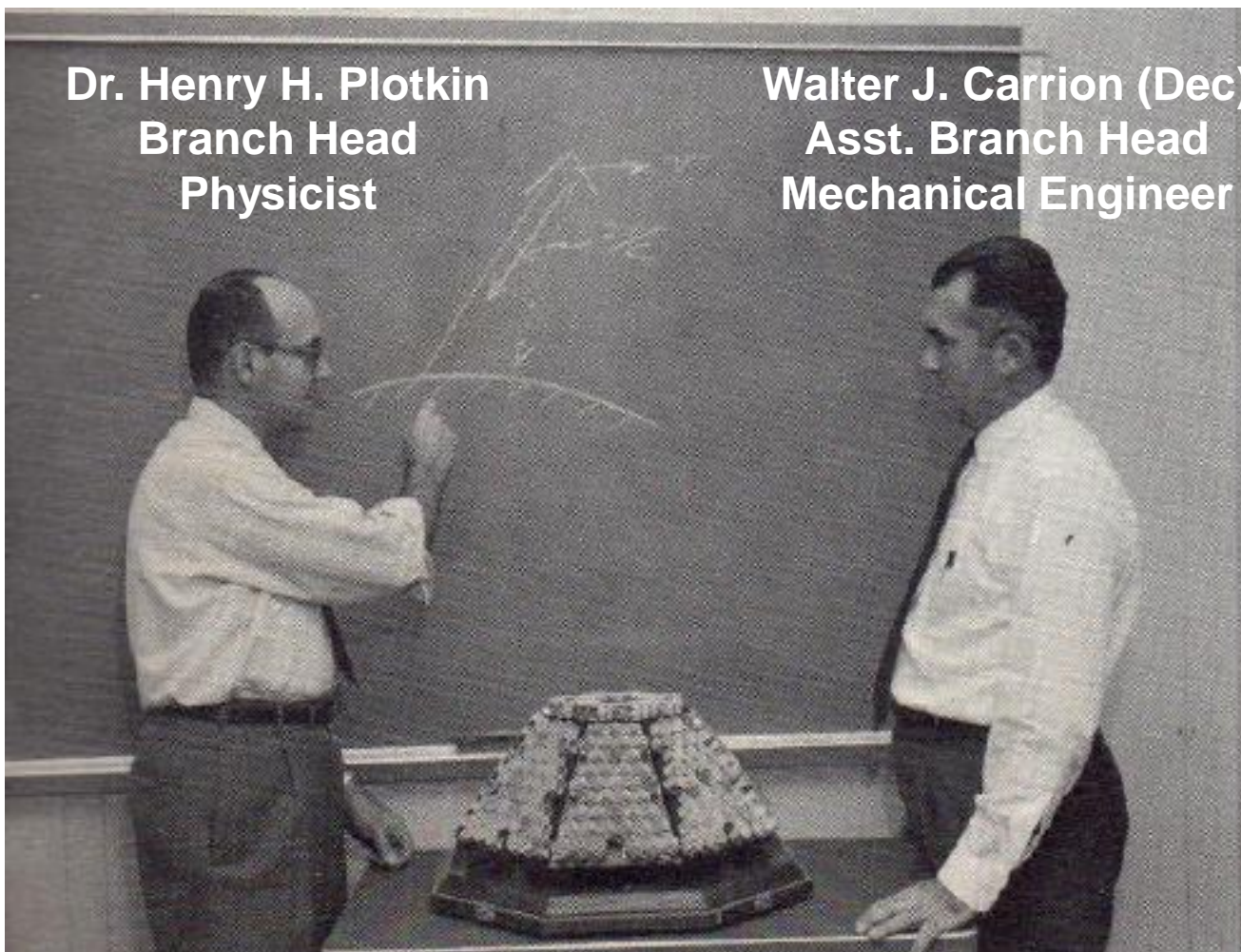

**GSFC Optical Systems Branch, Code 524**



# Goddard News, Nov. 30, 1964

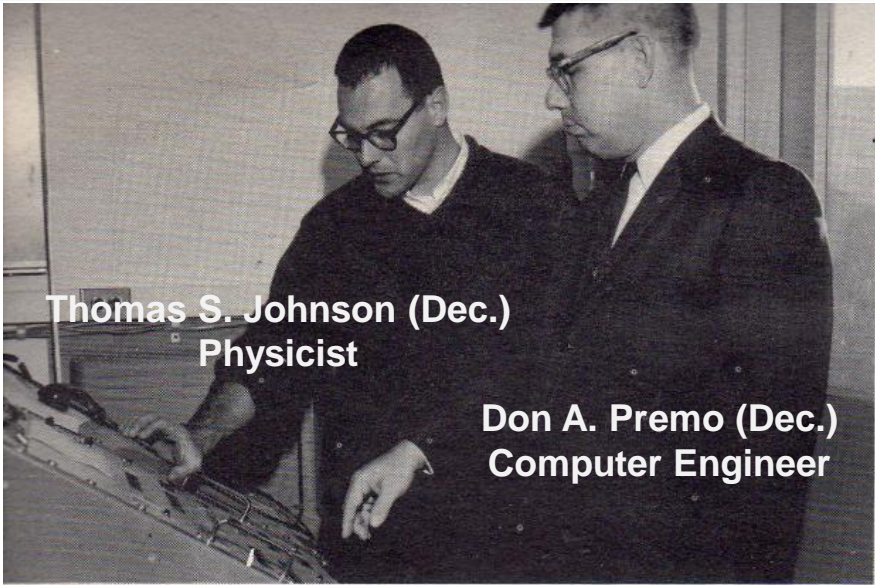

**Thomas S. Johnson (Dec.)**  
Physicist

**Don A. Premo (Dec.)**  
Computer Engineer

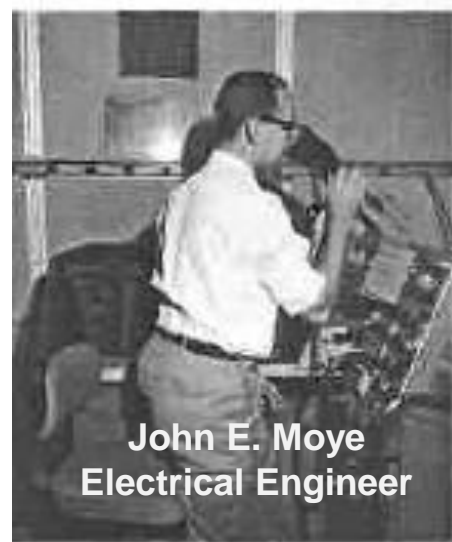

**John E. Moyer**  
Electrical Engineer



**Sol H. Genatt (Dec.)**  
Astronomer

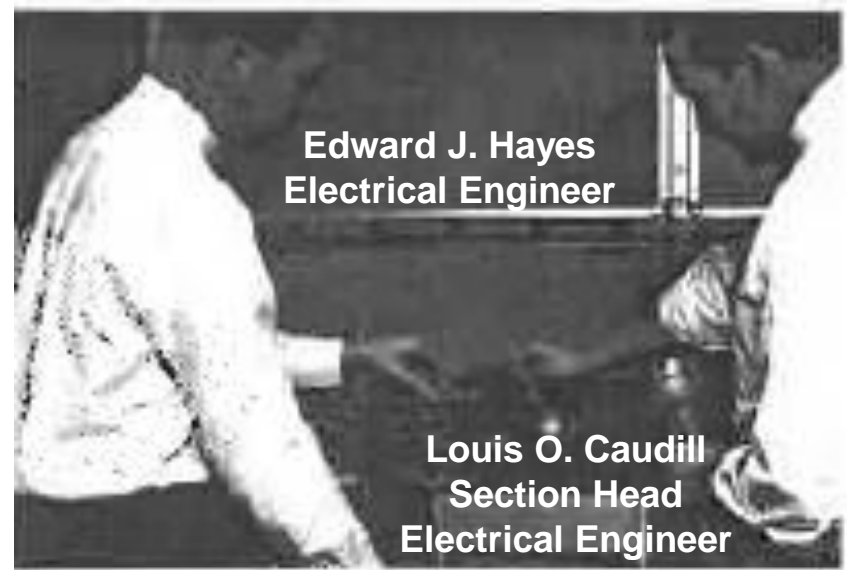

**Edward J. Hayes**  
Electrical Engineer

**Louis O. Caudill**  
Section Head  
Electrical Engineer

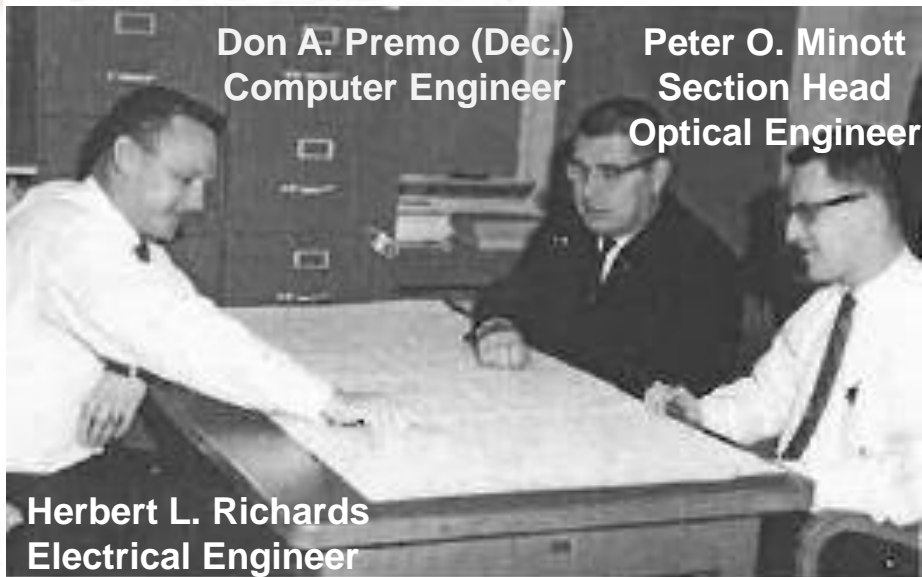

**Don A. Premo (Dec.)**  
Computer Engineer

**Peter O. Minott**  
Section Head  
Optical Engineer

**Herbert L. Richards**  
Electrical Engineer





# Goddard News, Nov. 30, 1964



**Charles J. Peruso**  
Laser Technician



**Paul L. Spadin**  
Laser Technician



**John J. Degnan**  
Physics Co-op Student



# Other Team Members



**Nelson McAvoy (dec.)**  
**Section Head**  
**Physicist**

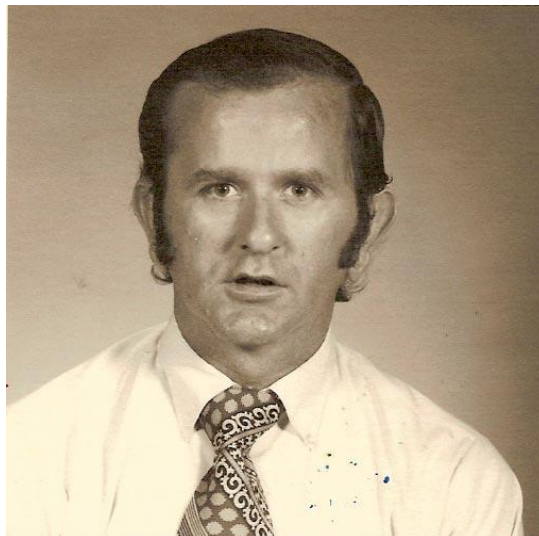

**Michael W. Fitzmaurice**  
**Electrical Engineer**

**Harold E. Walker (dec.)**  
**Technician**



# SLR Technology in the 1960s



- Laser: Rotating Mirror Q-switched Ruby (694 nm –red beam)
  - Energy: 0.8 J
  - Pulwidth: 20 nsec
  - Repetition Rate:1 Hz
- Detector: 9558A Photomultiplier
- Telescope: 16 inch primary guided by two operators on elevation and azimuth joysticks following sunlit satellite image
- No daytime ranging until 1969 when GSFC's Don Premo introduced computer control of the tracking mount.
- Ranging Accuracy: 3 to 1 m (compared to 50 to 75 m for best microwave radars of the period)
- First generation trailer-based Mobile Laser systems were developed by GSFC (MOBLAS 1 through 3)



# SLR Milestones in the 1960s



\* J. Degnan, 9<sup>th</sup> Intl. Workshop on Laser Ranging, Australia, 1994

- 1967 - First international SLR campaign launched . By this time, six retroreflector equipped satellites had been launched
  - NASA: Explorer 22, 27 29, and 36
  - CNES, France: Diadem 1 and 2
- Five SLR stations participated:
  - NASA: STALAS in Greenbelt , MD
  - France:
    1. Haute Provence, France;
    2. Colomb-Beshir, Algeria
    3. Stephanion, Greece
  - SAO: Organ Pass, New Mexico
- Science Achievements
  - Laser sites positioned within 5 m (a factor of 4 better than collocated Baker-Nunn optical observations)
  - SAO Standard Earth Gravity Model completed to degree and order 16 including 14 pairs of higher order coefficients.
- 1968 - SAO initiated 2<sup>nd</sup> international SLR campaign following launch of the GEOS 3 satellite. SAO prototype system installed at Mt. Hopkins Observatory, New Mexico. SAO Organ Pass system moved to Mt. Haleakala, Hawaii.
- 1969 - Apollo 11 astronauts placed first array on the Moon. The LUnar Ranging Experiment (LURE) team was the first to successfully record returns with the 2.7 meter telescope at the McDonald Observatory in Ft. Davis, Texas. The NASA-funded site at the University of Texas would be the primary provider of Lunar Laser Ranging (LLR) data for the next 15 years.





# SLR Milestones in the 1970s



- 1970- France launches PEOLE satellite. NASA funds new sub-meter accuracy SAO stations in Arequipa (Peru), Natal (Brazil) and Olifanstien (South Africa) to support new SAO/CNES science campaigns. The South Africa station was later relocated to the Orroral Valley in Australia
- 1971- First SLR collocation between NASA MOBLAS-1 and SAO Mt. Hopkins Observatory. Range biases of 1 to 2 meters were observed and were unstable.
- 1972 – Under the technical leadership of Prof. Karel Hamal of the Czech Technical University in Prague, the first SLR station in the Soviet INTERKOSMOS network became operational in Ondrejov, Czechoslovakia . Similar stations were later deployed at sites in Bolivia, Cuba, India, and Egypt.
- 1970 -1975: Four more arrays are landed on the Moon by Apollo 14 and 15 and the unmanned Soviet Landers Lunakhod 17 and 21. Soviet arrays were provided by France.
- 1973-1978 : European interest in SLR grows rapidly and the first three workshops are held in Greece (1973 and 1978 – George Veis) and Czechoslovakia (1975 – Karel Hamal)
- 1975-1976:First geodetic satellites dedicated to SLR
  - Starlette (France) in 1975
  - LAGEOS (NASA) in 1976
- 1975-1978 NASA launches first radar altimeters tracked by SLR for oceans research
  - GEOS-3 in 1975
  - Seasat in 1978 (Failed after only 3 months of operation)
- 1975-1979 NASA funds 2<sup>nd</sup> generation SLR Systems with <20 cm range precision
  - Fixed STAndard LASer (STALAS) at GSFC
  - Trailer-based MOBLAS 4 through 8
  - Highly Transportable Laser Ranging Systems (TLRS)
    - TLRS-1 at University of Texas at Austin (Dr. Eric Silverberg)
    - TLRS-2 at GSFC (Thomas Johnson)



# Starlette and LAGEOS



## Starlette

CNES, France

Launch: 1975

Diameter: 24 cm

Number of Retros: 60

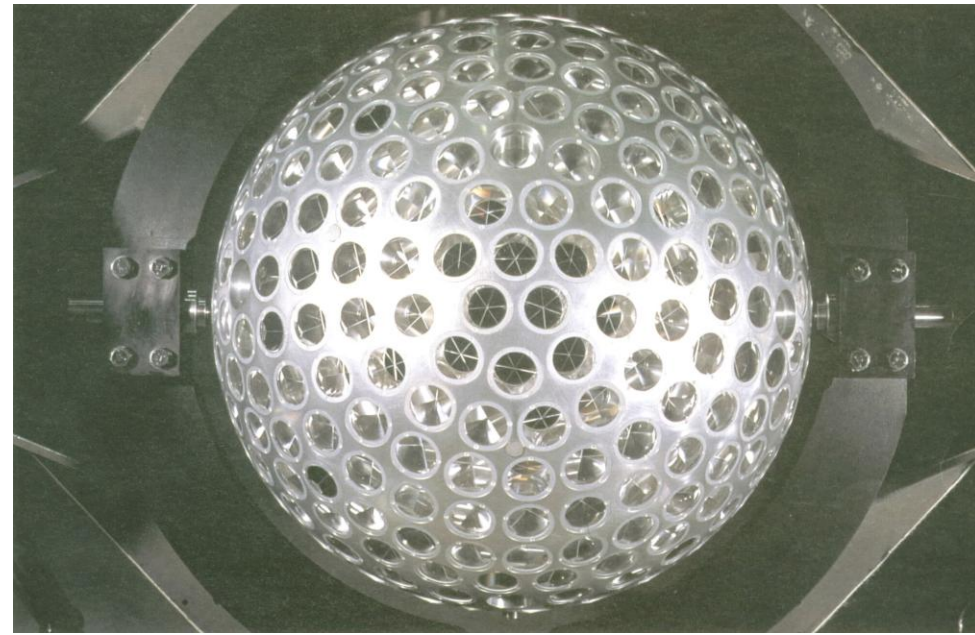

## LAGEOS

NASA, USA

Launch: 1976

Diameter: 60 cm

Number of Retros: 426 (4 Ge for NIR)

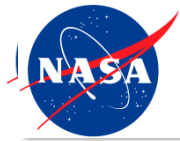

## 2nd Generation STALAS (STANDARD LASER)

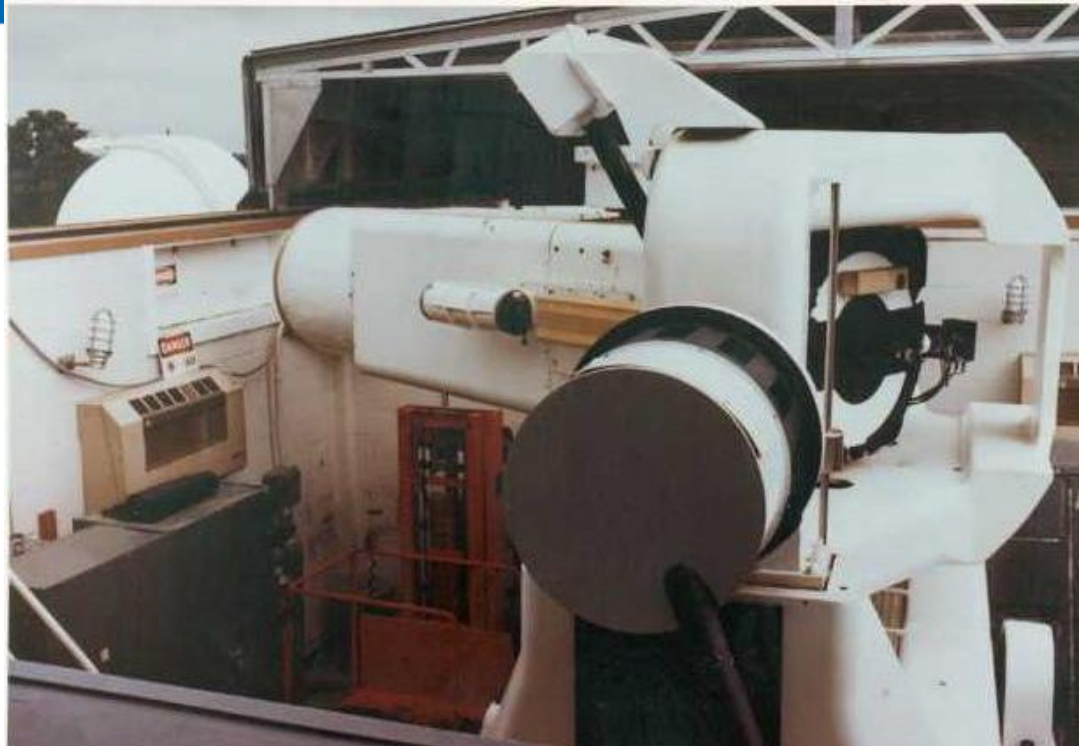

- Developed in early 1970s as the “NASA Standard” at the Goddard Optical Research Facility (GORF) which was later renamed the Goddard Geophysical and Astronomical Observatory (GGAO) in the 1990’s.
- X-Y mount with 61cm (24”) telescope.
- Initial system had 1 Hz, 20 nsec Q-switched ruby (694nm) laser and nominal 20 cm range precision
- STALAS broke the 10 cm barrier (7cm RMS range precision) in 1976 when a 100 psec pulsewidth actively modelocked Nd:YAG Laser/Regenerative Amplifier/ Multiple Single Pass amplifier was installed by John Degnan and the late H. Edward Rowe of GSFC.



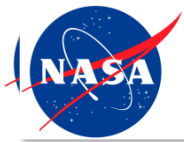

# Lunar Retroreflector Arrays



Five retroreflector arrays were placed on the lunar surface beginning with Apollo 11 in 1969. Two other manned Apollo missions (14 and 15) also left arrays with Apollo 15 being the largest (300 vs 100 cubes) to strengthen the return signal. Two unmanned Soviet Lunakhod (17 and 21) missions landed additional arrays provided by France.

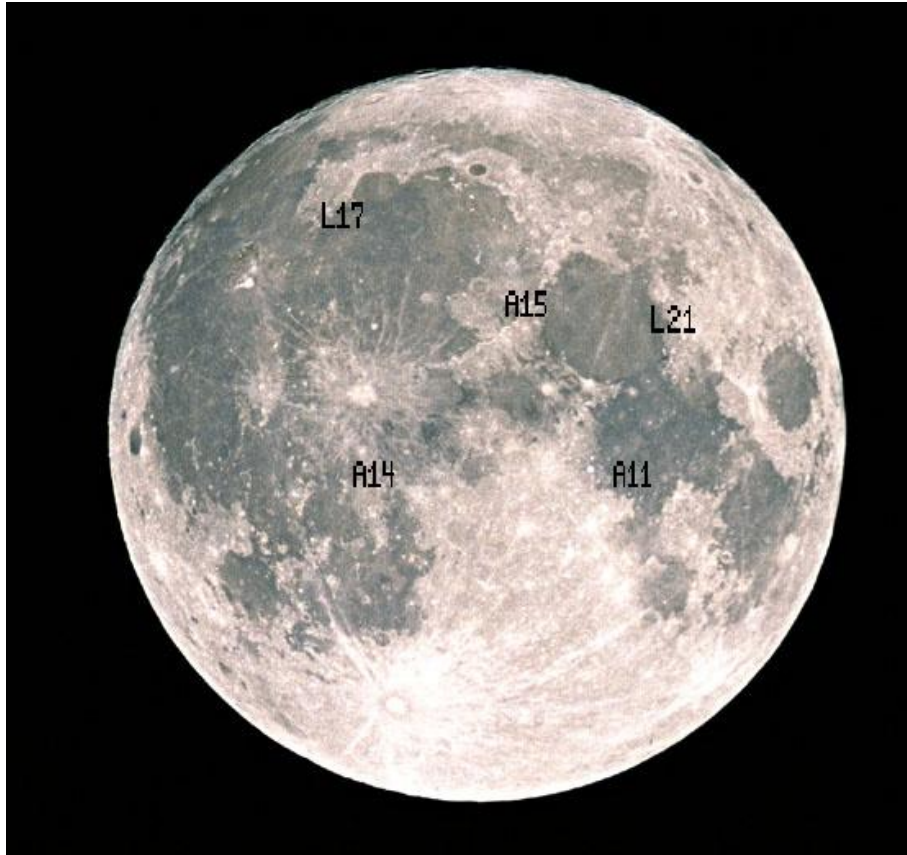

Retroreflector Array Sites

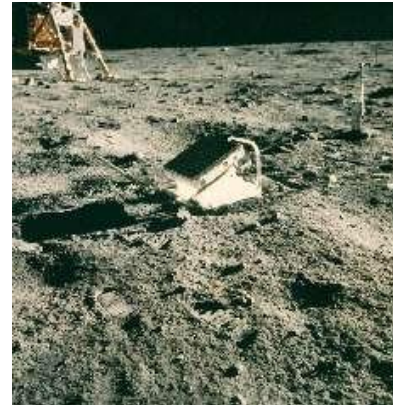

Apollo 11, 1969

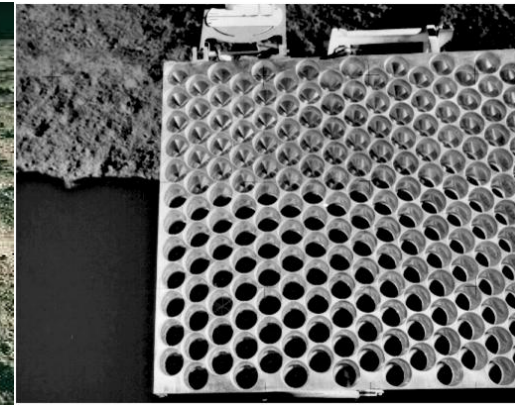

Apollo 15

Array



Lunakhod





# SLR Highlights in the 1980s



1979-NASA created the Crustal Dynamics Project (CDP) , GSFC Code 901, and transferred ownership of 5 MOBLAS stations ( 4 through 8) and 4 TLRs stations (1 through 4).

1981- Eric Silverberg of the University of Texas developed the first highly transportable SLR system housed in a camping van, TLRs-1. In parallel, GSFC's Thomas Johnson developed TLRs-2 which could be disassembled, loaded on an aircraft, and reassembled at remote Pacific islands such as Easter Island and French Polynesia. By the end of the decade, 6 highly transportable SLR systems -4 NASA TLRs 1-4), 1 German(MTLRs-1) , 1 Dutch (MTLRs-2), - were operating and performing regional measurements, alternating between Southern Europe and the Western US/Mexico. A 7<sup>th</sup> Transportable, Japan's HTLRs system surveyed several remote Japanese islands.,

1981 – 1985 Upgrades to the MOBLAS systems resulted in a single shot precision of 6 to 10 mm and a normal point precision of 1 to 2 mm. John Degnan and his GSFC/contractor team later redesigned TLR-2 and improved the single shot precision to 2.5 cm.

Major SLR developments in the former Soviet Union :

- Under the direction of Prof. Yuri Kokurin of the Moscow Lebedev Institute, three new stations were established at Semeiz and Katsively in the Ukraine and Riga, Latvia.

- Launch of several retroreflector-equipped satellite series (Geoica, GLONASS, and ETALON) with tracking supported by 25 transportable and 5 fixed SLR stations across the Soviet Union.

- Two new LLR stations were developed to compete with MLRS: CERGA LLR at Grasse in Southern France and a NASA funded site on Mt. Haleakala operated by the University of Hawaii.



# NASA's Crustal Dynamics Project (CDP) 1979-1991



- **GSFC Project Scientist:**
  - Dr. David E. Smith
- **Deputy Project Scientist:**
  - Dr. Herbert Frey
- **GSFC Project Manager:**
  - Dr. Robert Coates (1979-1989)
  - Mr. John Bosworth (1989-1991)
- **Deputy Project Manager:**
  - Mr. John Bosworth (1979-1989)
  - Dr. John Degnan (1989-1991)
- **Operated as an office (Code 901) in the GSFC Earth Science Directorate**
- **Provided a programmatic focus for the international Earth science community**
- **Provided the necessary financial, facilities, and manpower for the study of tectonic plate motion on a global scale**
- **Relied on GSFC's global SLR and VLBI networks for geodetic measurements**
- **Financed the upgrade of third generation, cm accuracy MOBLAS SLR systems and the highly transportable TLRs systems (TLRS-1 through 4)**



# NASA CDP SLR Stations and Locations (1992)



## TLRS 3 & 4

- Arequipa, Peru
- Mt. Haleakala, Hawaii, USA



## MOBLAS 4-8

- GSFC, Maryland, USA
- California, USA
- Yarragadee, Australia
- Tahiti, French Polynesia
- South Africa



**HOLLAS (operated by Univ. of Hawaii)**  
Mt. Haleakala, Maui, Hawaii, USA (SLR & LLR)  
(decommissioned in 1992)



**MLRS (operated by Univ. of Texas at Austin)**  
McDonald Observatory, Ft. Davis, Texas, USA  
(SLR & LLR)



# MOBLAS 4 Upgrade



- **Laser: Quantel PTM Q-switched mode-locked Nd:YAG plus amplifiers**
  - Energy: 100 mJ @ 532 nm
  - Pulsetwidth: 100 psec
  - Repetiton Rate: 5 to 10 Hz
- **Detector: Bialkali Microchannel Plate Photomultiplier (developed by Bruce Johnson of ITT)**
  - Risetime 170 psec
  - QE: 10 to18%
  - <3mm transit time jitter
- **Event Timer: Hewlett-Packard 5370B**
  - Resolution: 20 psec
- **Ranging Precision**
  - single shot RMS: 6 to 10 mm
  - Normal Points:1 to 2 mm
- **Crew size per shift: 3-4**

## Key GSFC Contributors

John Degnan

Tom Zagwodzki

H. Edward Rowe (dec)

Tom Varghese and his  
HTSI staff





# Global Tectonic Plate Motion



High, low drag satellites, like LAGEOS in a 6000 km high orbit, provide a stable inertial reference frame which allow us to see changes in relative positions of SLR stations that track them and thereby monitor tectonic plate motion.

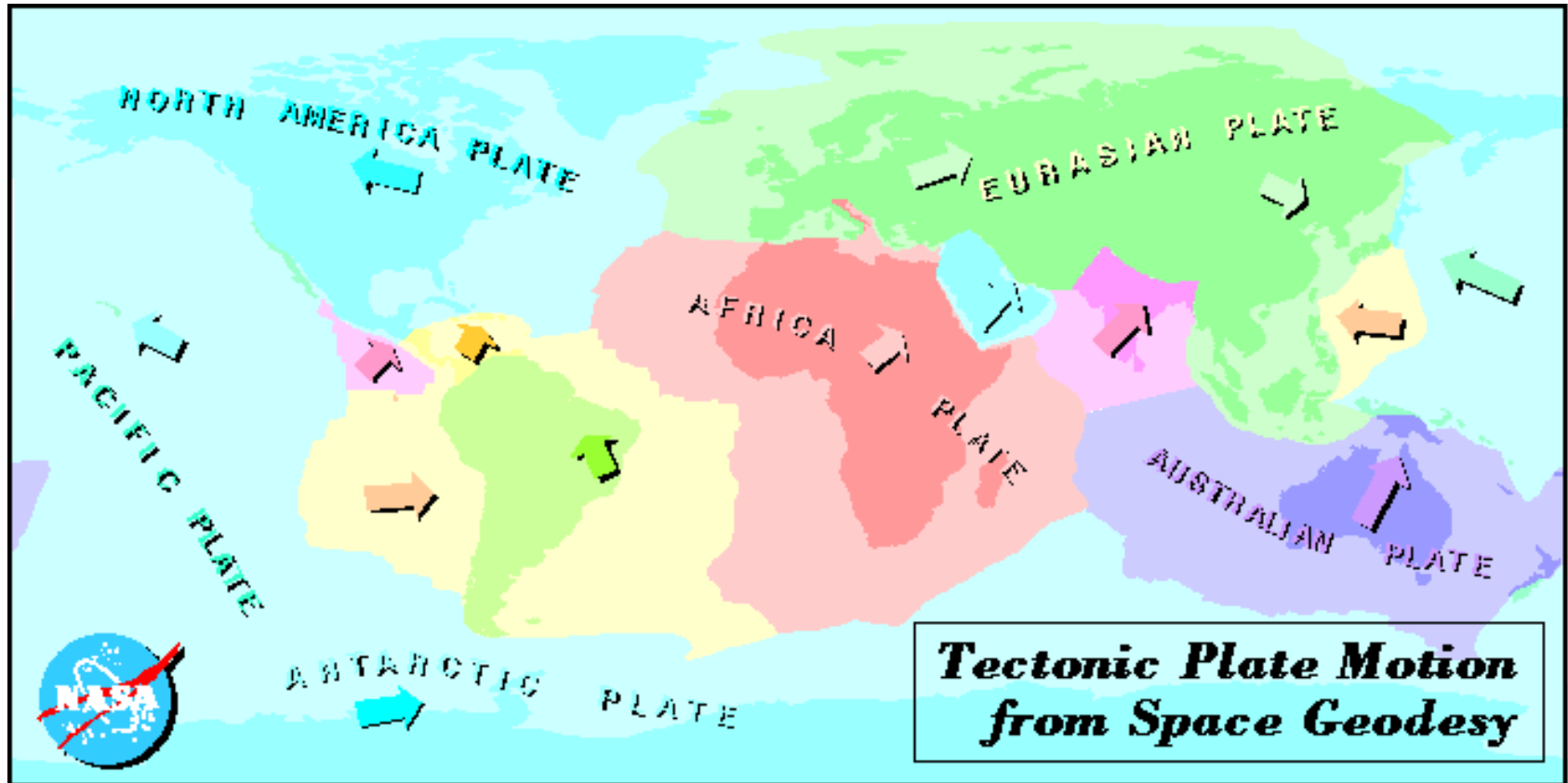

Length of the arrows are an indication of relative velocity.



# SLR Site Motion in Europe

## CDP/WEGENER-MEDLAS Campaigns

US and European SLR transportables routinely alternated between sites in the Western US and the Mediterranean to monitor the complex motions near major fault lines.

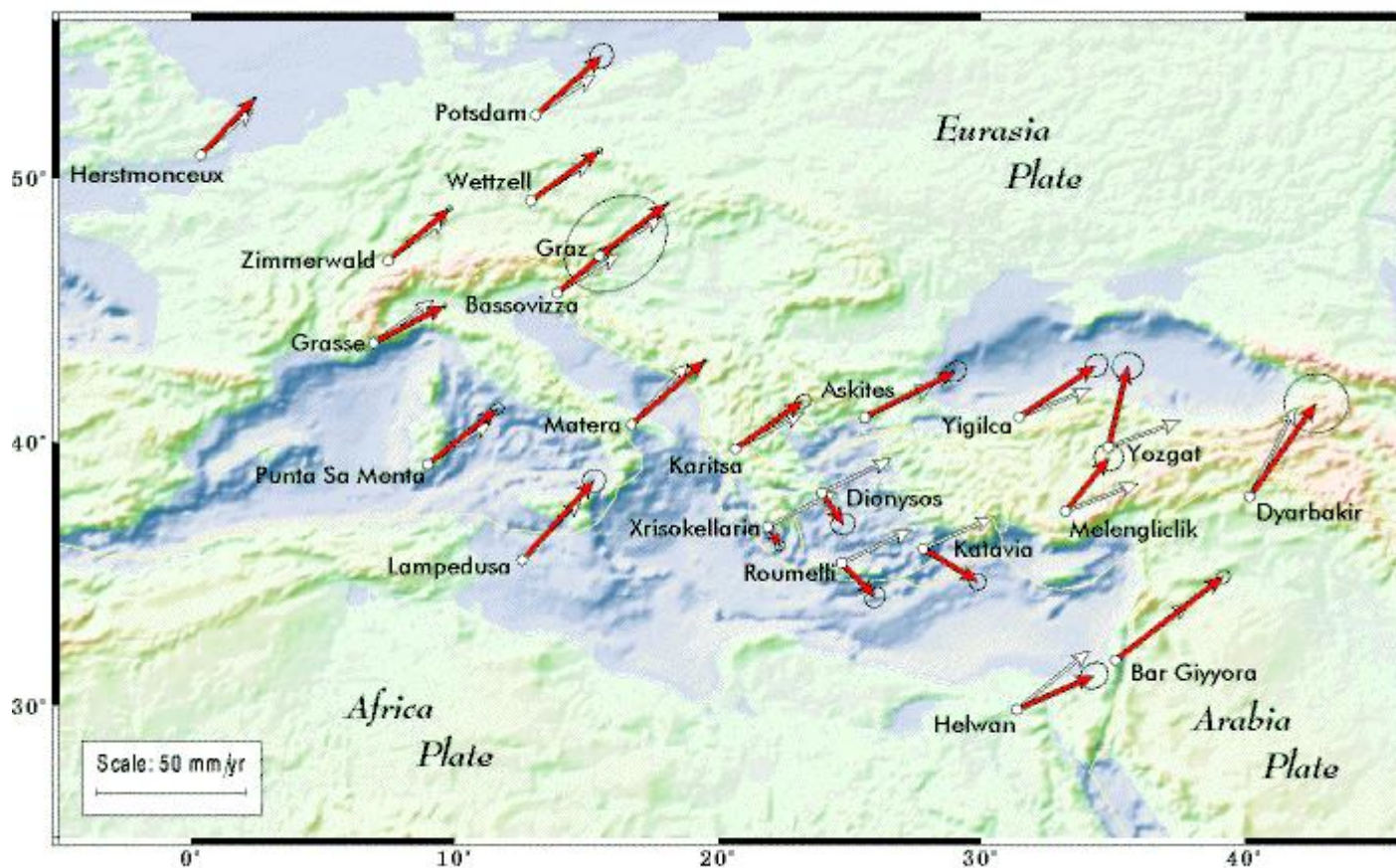



## CDP/WEGENER Campaigns

Regional deformation measurements were enabled by the development of highly transportable SLR stations in the US and Europe. This function has since been largely taken over by GPS with most SLR transportables now either in fixed locations or doing specialized investigations.

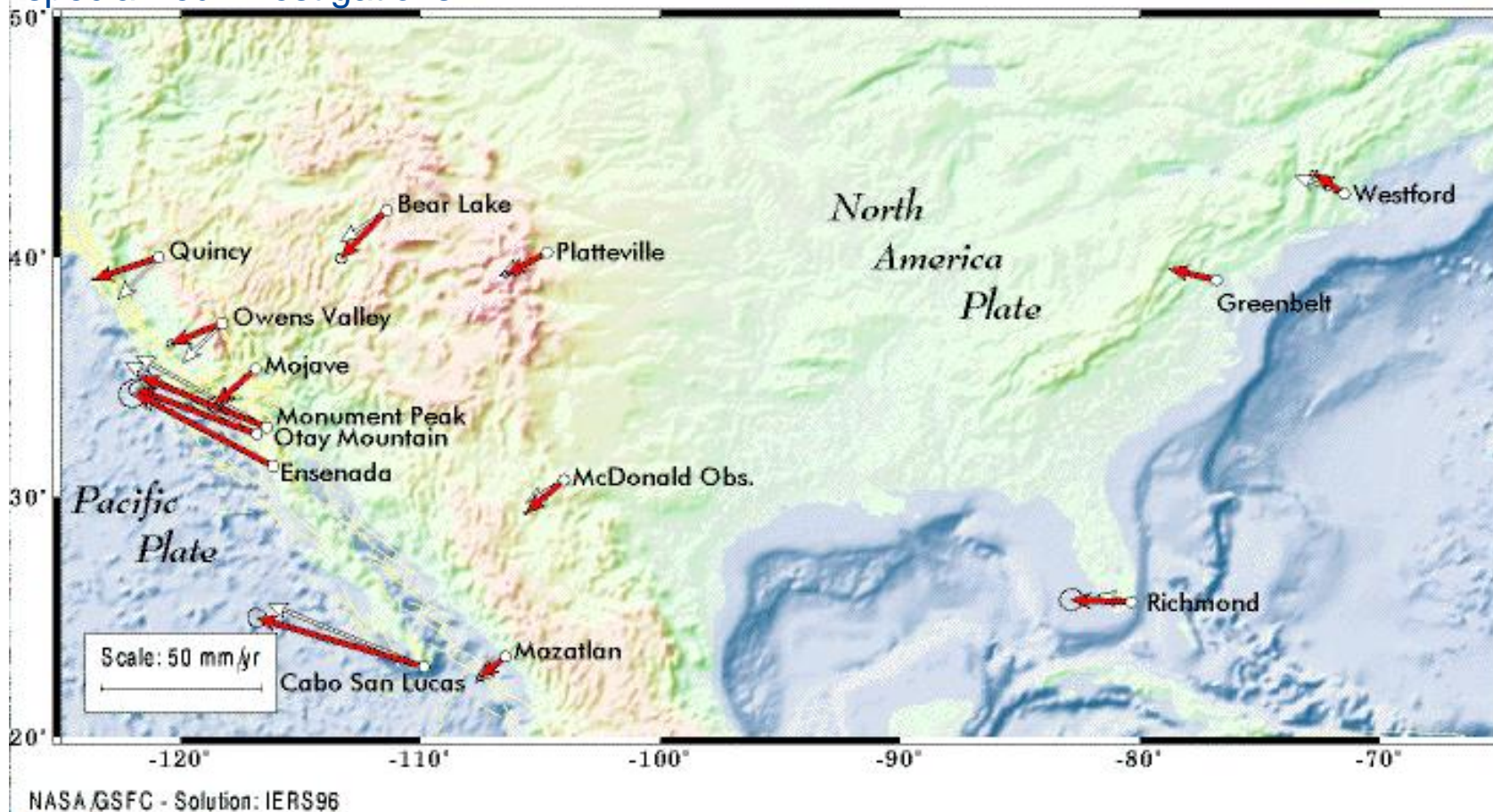

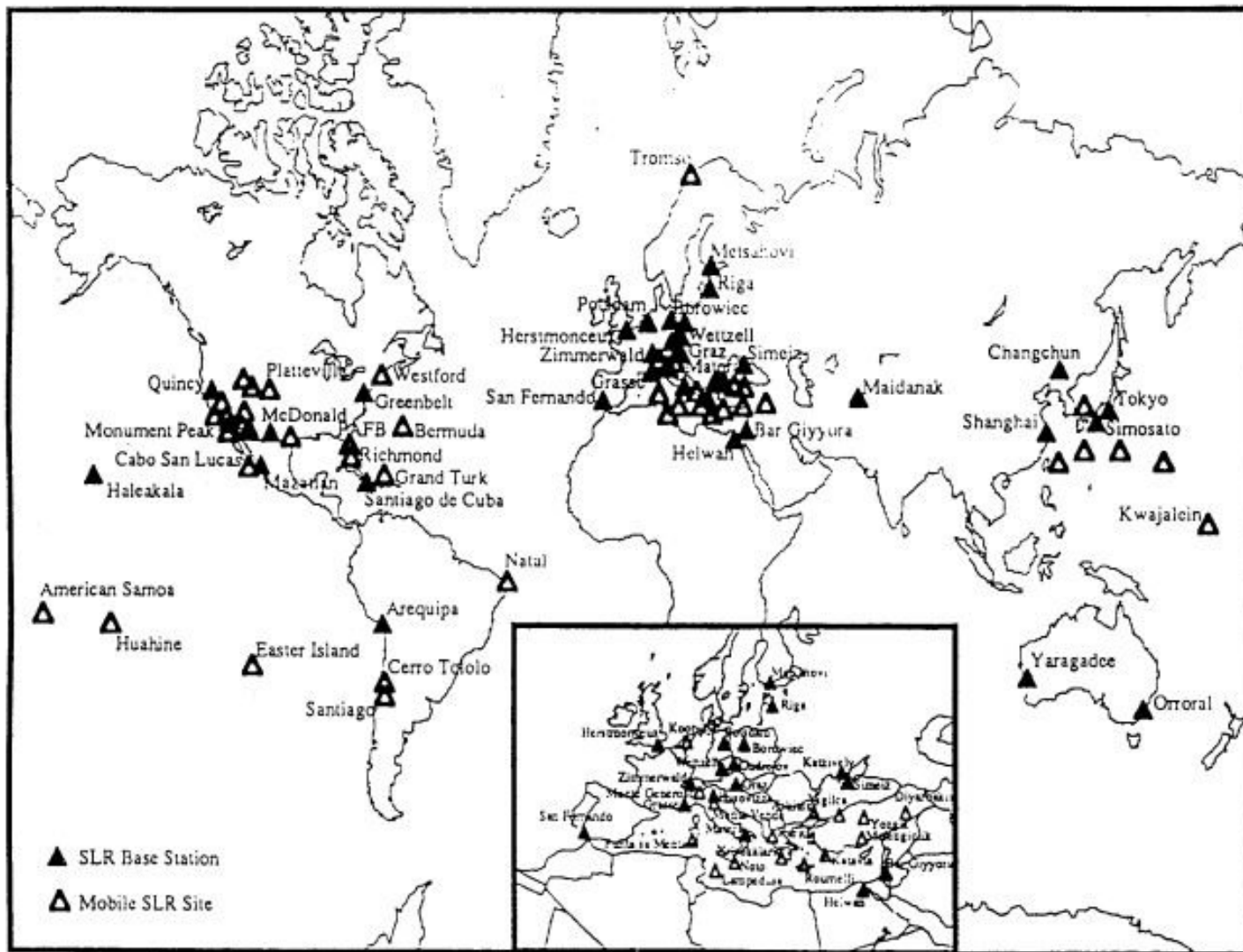

Fig. 1. International satellite laser ranging sites - fixed and mobile.





# SLR Highlights in the 1990s



- Following conclusion of the CDP, NASA space geodetic operations were integrated into the Laboratory for Terrestrial Physics under Dr. David Smith (Codes 920.1 and 920.3)
- During this period, the role of less expensive, ground-based and space-based differential Global Positioning System (GPS) receivers in global space geodesy grew rapidly. JPL managed the NASA GPS program. SLR provided early test support, validation, and backup of GPS flight units.
- NASA SLR operating budgets began to fall drastically at a time when an increasing number of satellites required precise SLR tracking round the clock
  - ESA Earth Resources Satellites (ERS-1 and ERS-2) in 1991 and 1995
  - NASA/CNES TOPEX/Poseidon and LAGEOS- 2 (Italy) in 1992
  - Geosat Followon (US Navy) in 1998
  - JASON-1 (NASA/CNES) in 2003
- The new oceanographic satellites required cm orbits and extensive temporal coverage to meet their science goals. Reduced operating costs replaced improved range precision as NASA's principle technology goal for SLR.
- The Joint US/French TOPEX/Poseidon Project, managed for NASA out of JPL, provided additional resources which were allocated to much needed SLR tracking mount refurbishment, extra SLR shifts, and increased station automation. SLR took over POD when the onboard GPS system failed.
- During the decade, NASA SLR manpower was reduced from 3 or 4 to 1 per shift but data output quadrupled. Even with 1 operator per shift, each station required 4 people for 24/7 ops
- A concept for an autonomous, eyesafe SLR2000 was proposed by John Degnan at the Belmont Workshop in 1994. First substantial funding was provided in late FY98.



- **At the urging of Gerhard Beutler (Switzerland), the ILRS was created in 1998 by John Degnan (GSFC) and Bob Schutz (Univ. of Texas at Austin) as a successor organization to the CSTG Satellite and Lunar Laser Ranging Subcommittee. ILRS was later designated an official service of the International Association for Geodesy (IAG)**
- **The ILRS coordinates the SLR activities of approximately 30 countries in mission planning, tracking, data formatting and analysis, technology development, etc.**
- **ILRS Central Bureau resides at NASA Goddard Space Flight Center (GSFC) in Greenbelt, MD**
  - **First Director: John Bosworth (GSFC); Current: Dr. Michael Pearlman (SAO)**
  - **First Secretary: Dr. Michael Pearlman (SAO); Current: Carey Noll (GSFC)**
- **16 Member International Governing Board sets policy**
  - **Board members are either appointed or elected by their peers and chairperson is elected by Board members**
  - **GB Chairpersons: John Degnan (GSFC/USA); Werner Gurtner (Switzerland-dec.); Graham Appleby (UK); and Guiseppe Bianco (Italy)**



# SLR Trends in the New Millennium



- **Accuracy Goal: 1mm accuracy normal points in support of international science goals as set by the Global Geodetic Observing System (GGOS).**
- **High Level of Station Automation**
  - Semi-automated: Single Operator and/or Remote Operation (many modern stations have achieved this)
  - Reduced operating costs and increased productivity
- **Higher Repetition Rates (100 Hz to 2000 Hz)**
  - Single photon, 2 kHz systems
    - pioneered by NASA SLR2000 system; later redubbed Next Generation Satellite Laser Ranging (NGSLR) by NASA Space Geodesy Project
    - Operating successfully in US (NGSLR), Austria (Graz), UK (Herstmonceaux), China, etc.
    - Some stations took advantage of single photon sensitivity to track space debris
  - Multiphoton, 100 Hz systems replacing legacy systems in Russian networks
  - Can achieve mm accuracy normal points over shorter time period ( $1/\sqrt{N}$ ) allowing more satellites to be tracked per day to cope with increasing tracking demands
- **SLR data is being utilized in combination with VLBI, GNSS and DORIS data to yield more robust Earth science results**



# NASA SLR2000/NGSLR



- SLR2000 concept, based on kHz systems and photon-counting, proposed by John Degnan at 1994 Belmont Workshop
- First substantial NASA HQ funding provided in FY98
- GSFC Civil Service Team (Code 920.3)
  - John Degnan (PI to Jan 2003)
  - Jan McGarry (PI from Jan 2003-present)
  - Thomas Zagwodzki
- Local Contractor Support over the years
  - HTSI
  - Orbital Sciences Corporation
  - Raytheon
  - Sigma Space
  - Cybioms
- First successful daylight tracking of TOPEX-Poseidon in 2003.
- Day/night laser tracking to satellites up to 22,000 Km slant range (GPS, GLONASS, ETALON) with mm precision normal points.
- Successful collocation with NASA standard MOBLAS-7 completed in 2013.
- NGSLR serves as prototype for new Space Geodesy Satellite Laser Ranging System (SGSLR) Network







# Observing Satellite Rotation with Single Photons

Courtesy: Georg Kirchner, Graz SLR, Austria

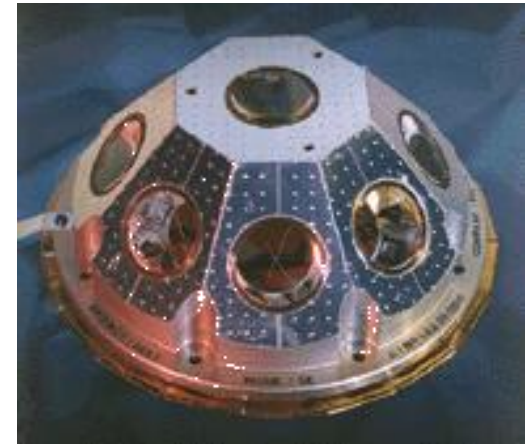
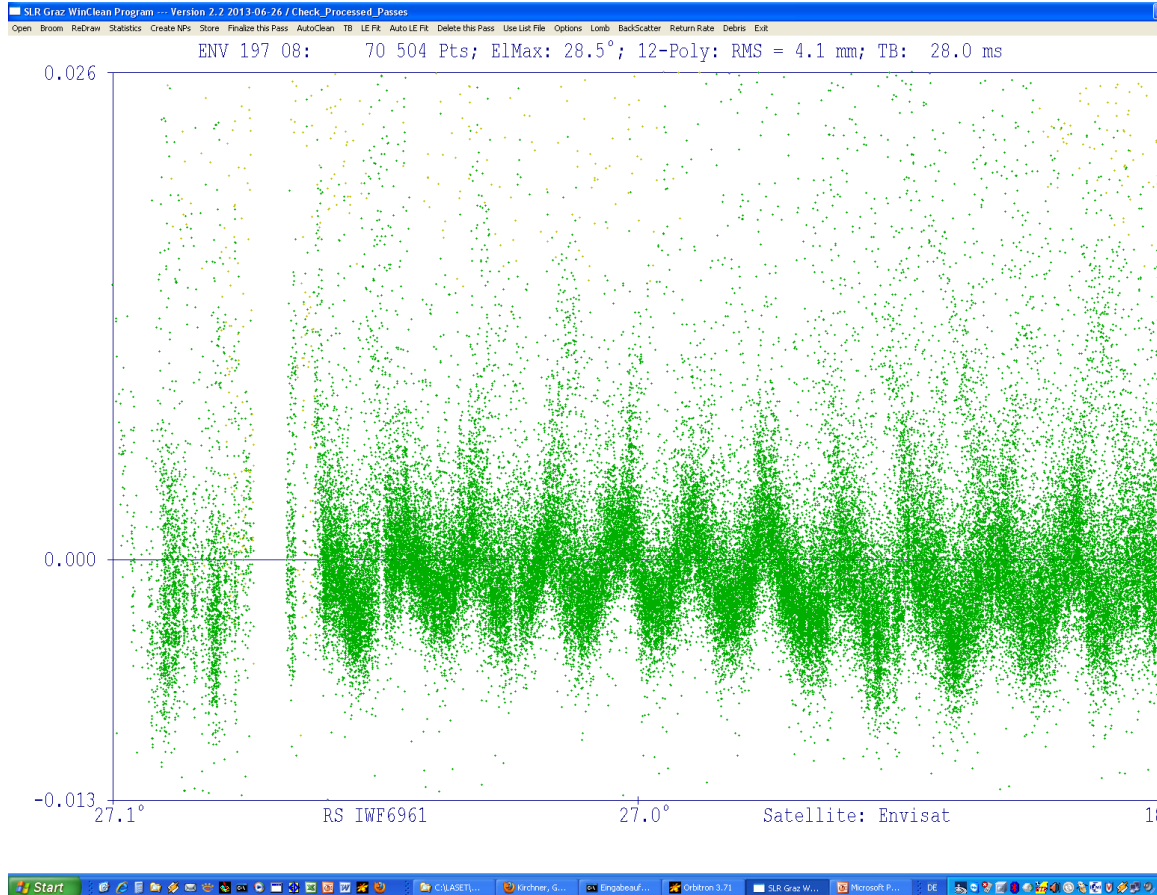

ENVISAT Retro Array

Graz Laser Characteristics:  
Energy: 0.4 mJ @ 532 nm  
Pulsewidth: <20 psec  
Fire Rate: 2 kHz  
50 cm receive telescope

Ultra short pulses at kHz rates greatly increase temporal and spatial (range) resolution and allow one to see individual retroreflectors as the satellite rotates.





# Representative SLR Precision vs Time

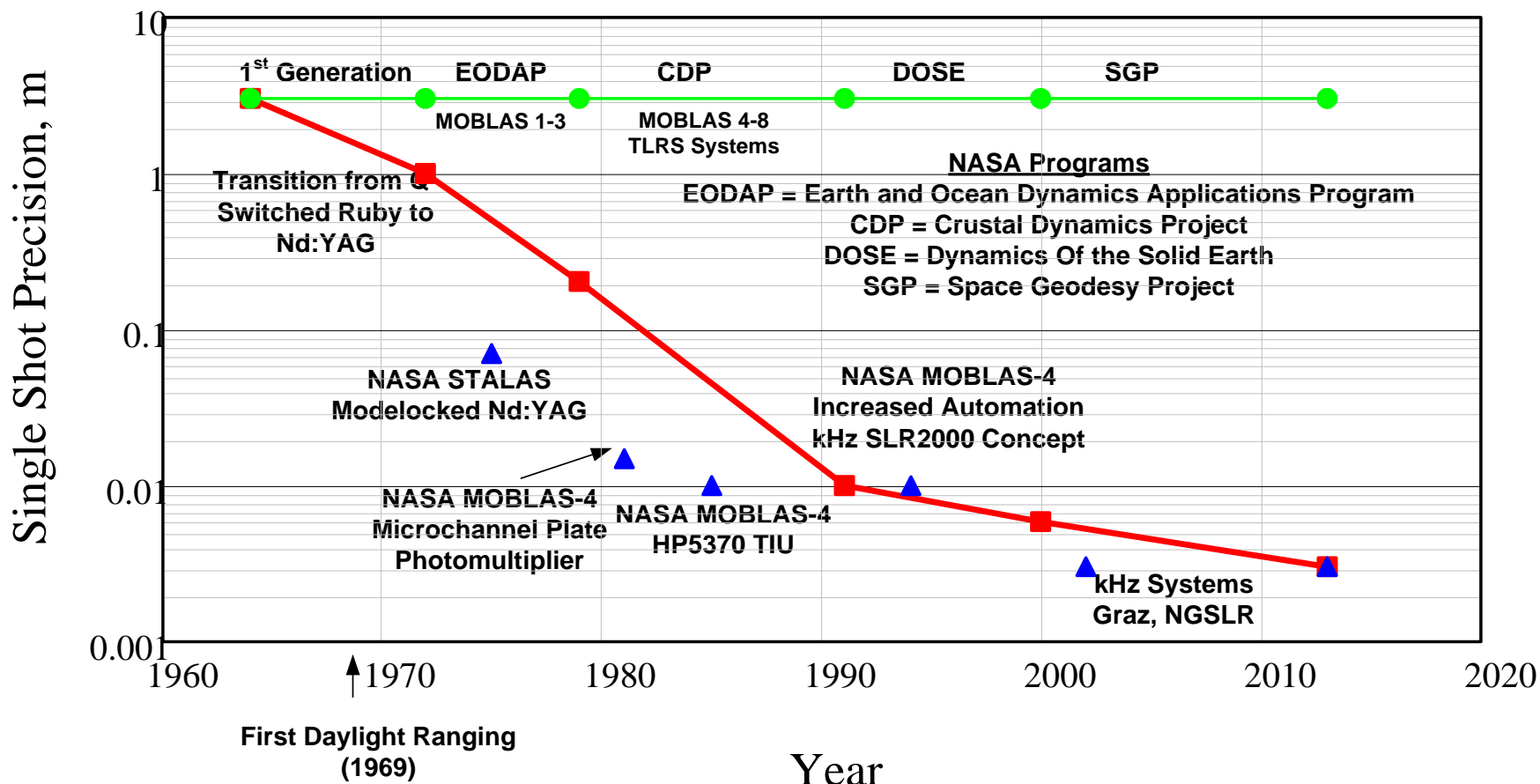



# Current ILRS Network\*



The 37 station SLR network has grown substantially from only 5 US and French stations in the late 1960s but there are still some coverage gaps in the Southern Hemisphere, Equatorial Region, and the polar regions.

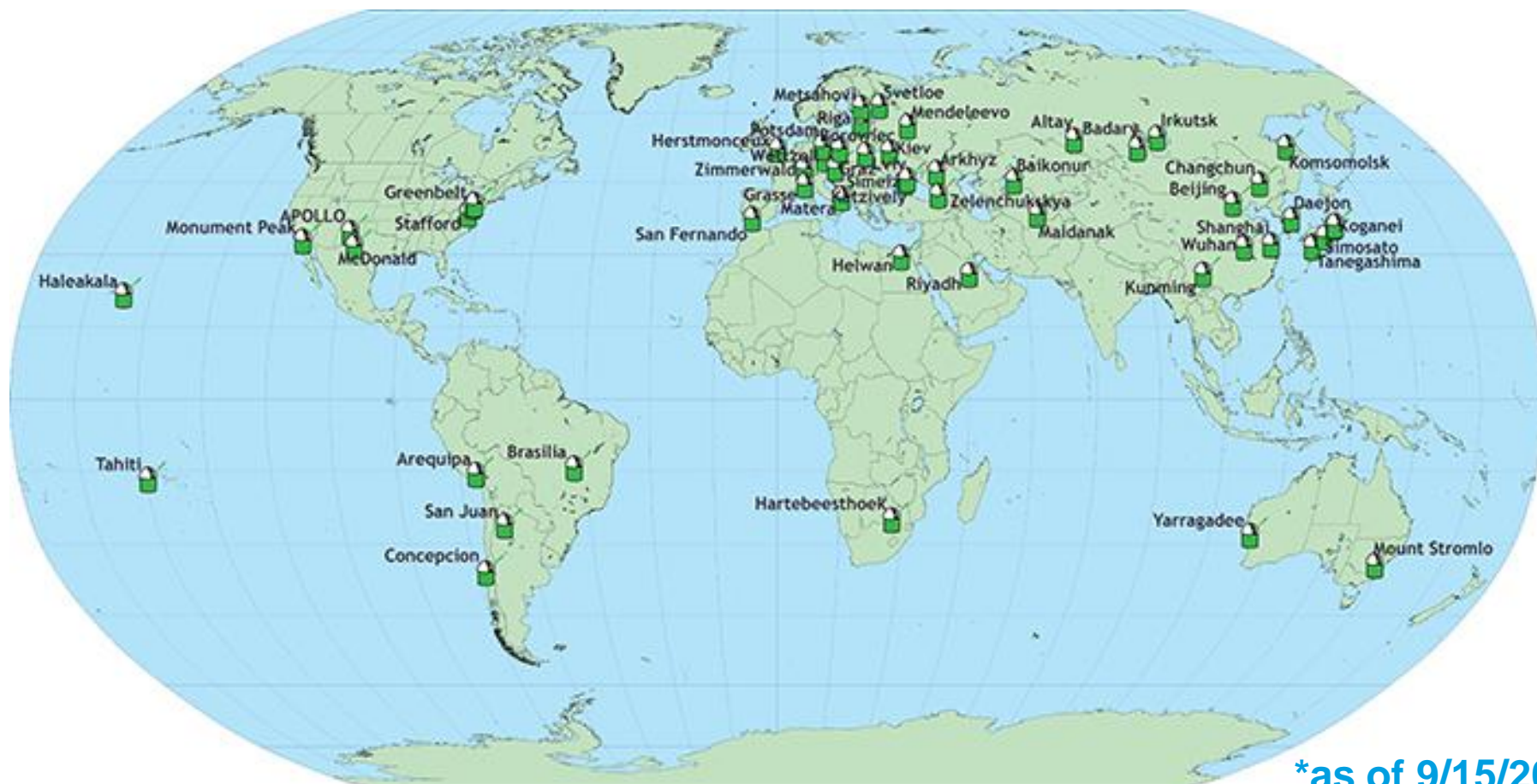

\*as of 9/15/2014



# Space Missions Tracked by SLR\*



\* ~ 75 satellites as of June 10, 2013

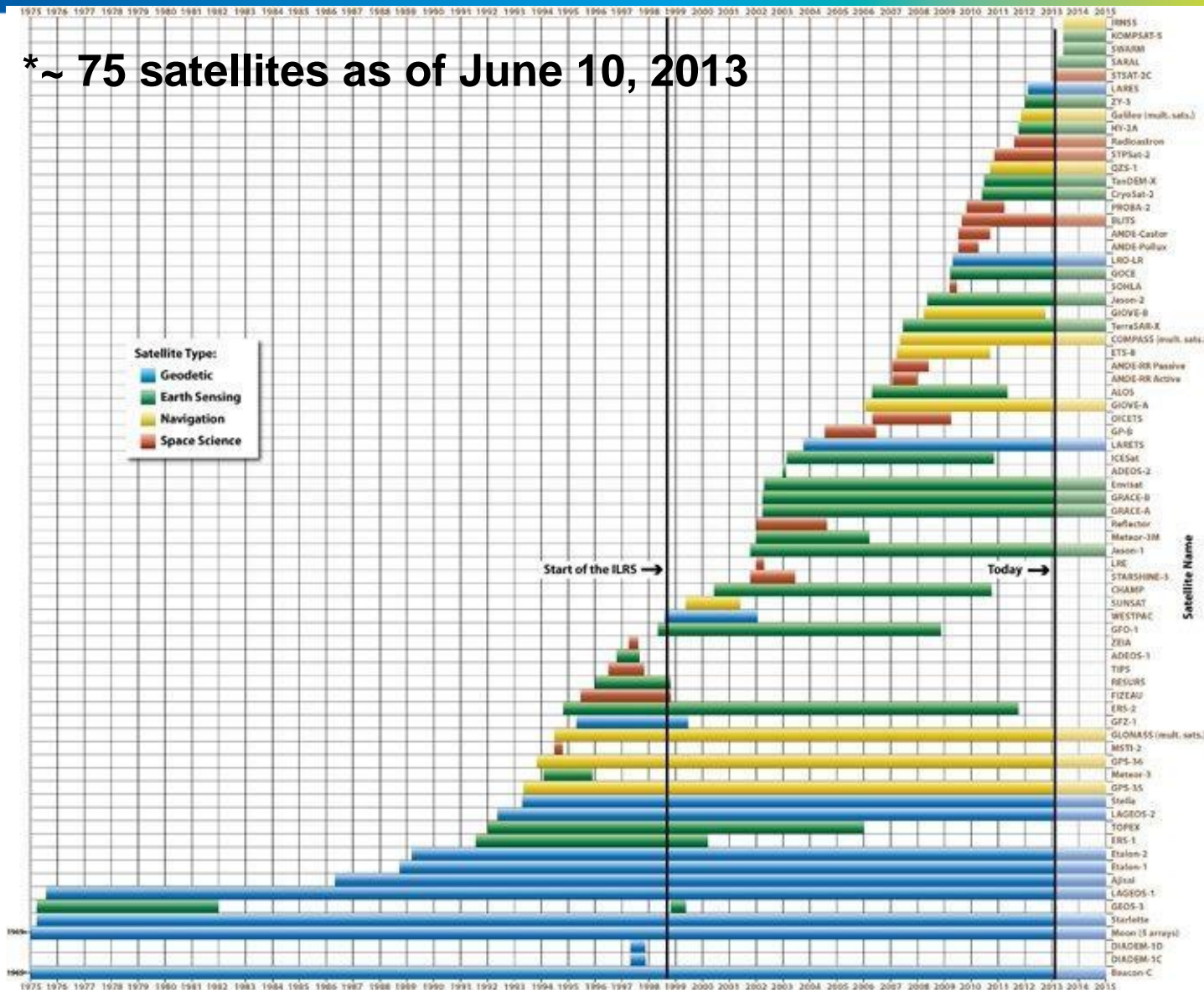



# SLR Missions and Orbits

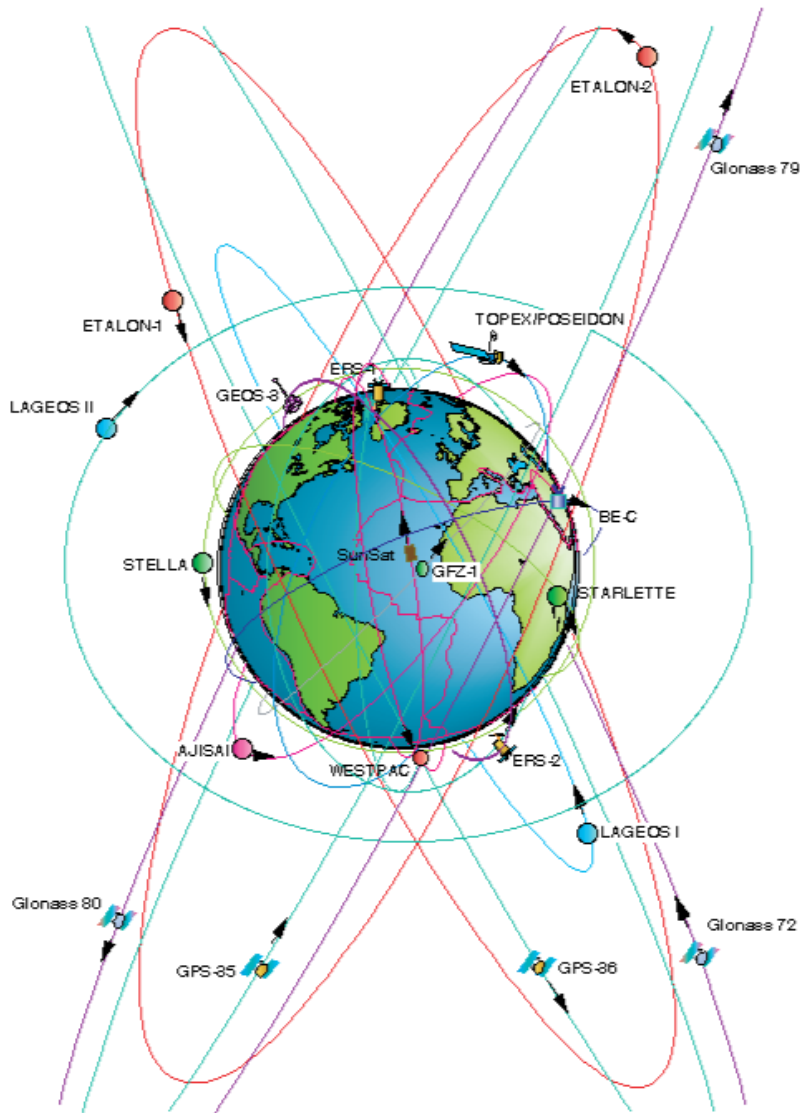

The SLR constellation spans a wide range of altitudes and inclinations and each retroreflector array has to be designed accordingly based on mission goals, desired signal strength, etc.





# Laser Debris Ranging 2013

Courtesy: Georg Kirchner, Graz, Austria

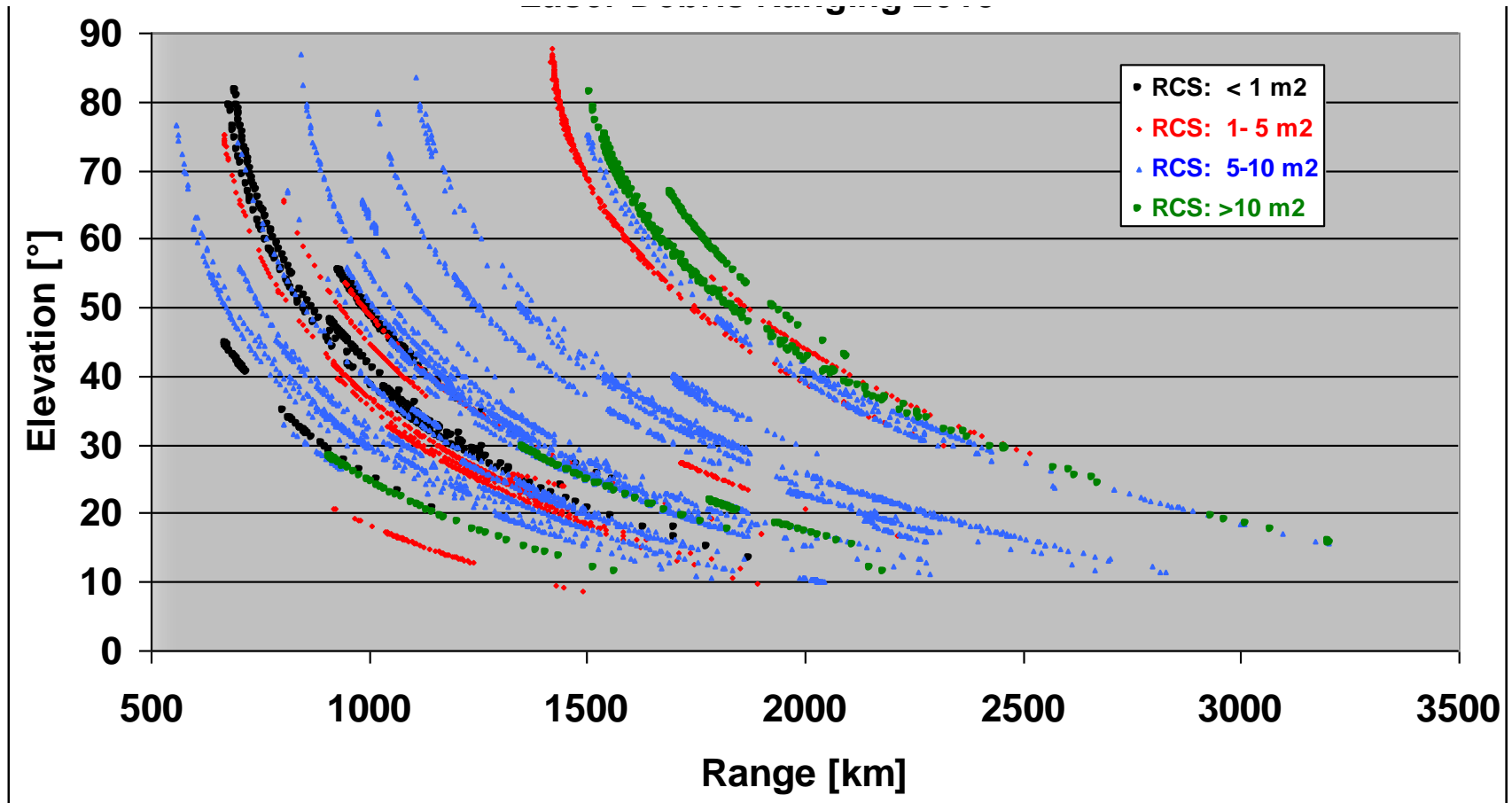

2013: In 13 Sessions – each about 2 to 3 h during early evening - >200 passes of about 60 objects measured; up to 3000 km distance . RCS = Radial Cross Section. Pulse Energy: 200 mJ; Pulwidth: 3 nsec; Fire Rate: 80 Hz. Flashlamp-pumped.



# EUROPEAN MULTISTATIC EXPERIMENT

Courtesy: Georg Kirchner, Graz, Austria



Graphics: © Peter Ruzek / AIUB

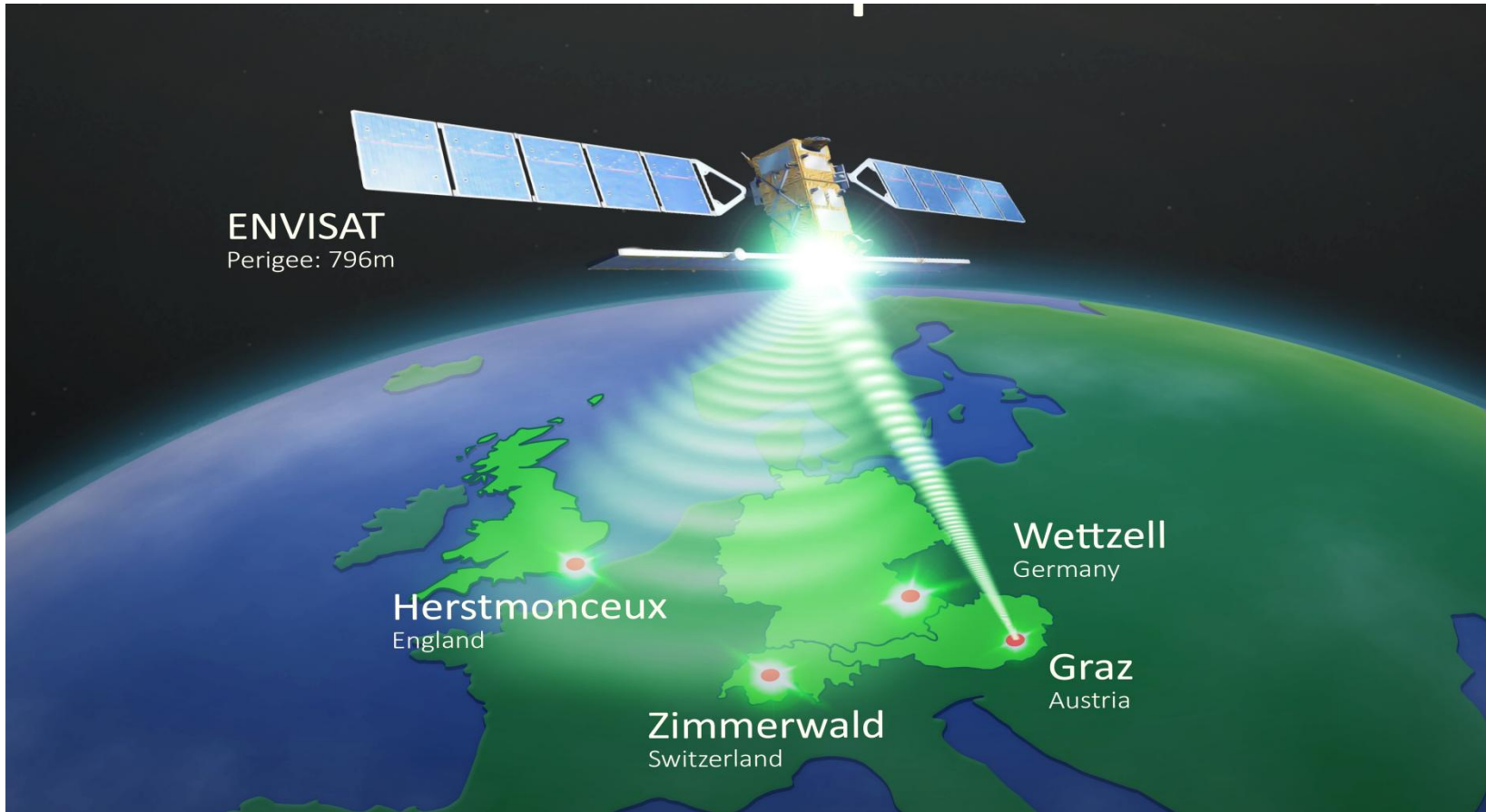

- ONE ,active‘ station (Graz) fires laser Pulses
- photons are reflected diffusely from satellite
- SEVERAL ,passive‘ stations receive these photons

- Distance Graz – Zimmerwald: 600 km
- Distance Graz – Wettzell: 400 km
- Distance Graz – Herstmonceux: 1200 km

LWF/ÖAW GRAZ



# Austrian Photons off Space Debris Detected in Germany

Courtesy: Georg Kirchner, Graz SLR



## WETTZELL detects Graz Photons 2013-09-24 007 / SL-16 R/B (23088); RCS: 11.2 m<sup>2</sup>

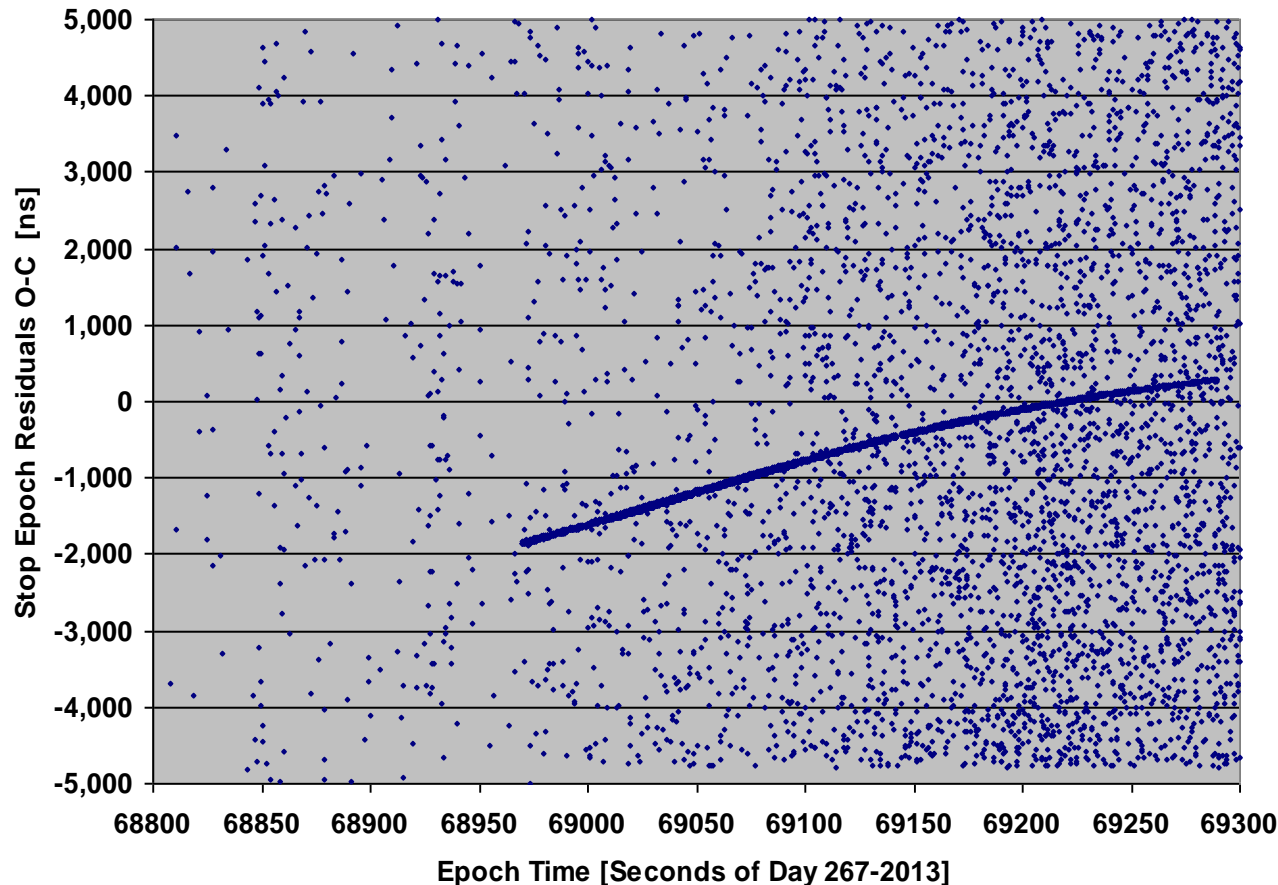

- Example: Graz fires to an old rocket body: 11 m<sup>2</sup> Radar Cross Section (RCS)
- Photons are reflected diffusely and detected in Wettzell: Clear signal visible ...
- Distance: 1800 to 2500 km  
Elevation: 20° to 10° ↓  
(as seen from Graz)
- Debris Laser Firing Rate: 80 Hz
- Maximum Pulse Energy 200 mJ @ 532 nm
- Laser Pulwidth: 3 nsec
- Flashlamp Pumped



# SLR TRF Origin (ITRF2013)\*



\* Courtesy, Erricos Pavlis, UMBC/GSFC

SLR defines the origin of the Terrestrial Reference Frame (TRF), i.e., the Earth Center of Mass (Geocenter) and monitors its movement over time.

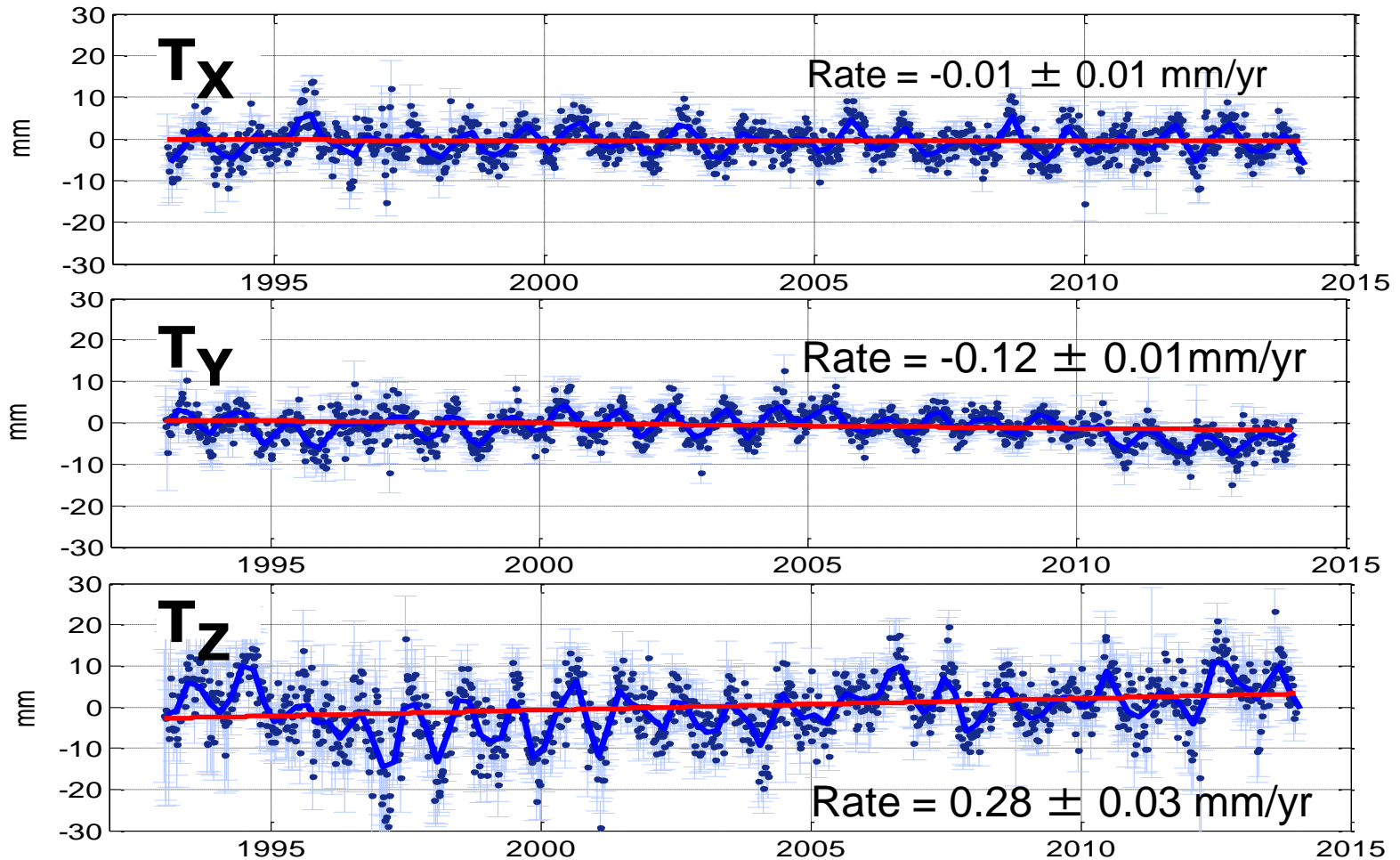





# SLR TRF Scale (ITRF2013)



\* Courtesy, Erricos Pavlis, UMBC/GSFC

TRF Scale is defined as the product  $GM$  where  $G$  is the gravitational constant and  $M$  is the mass of the Earth. Scale is also a measure of the positional stability of the overall SLR network.

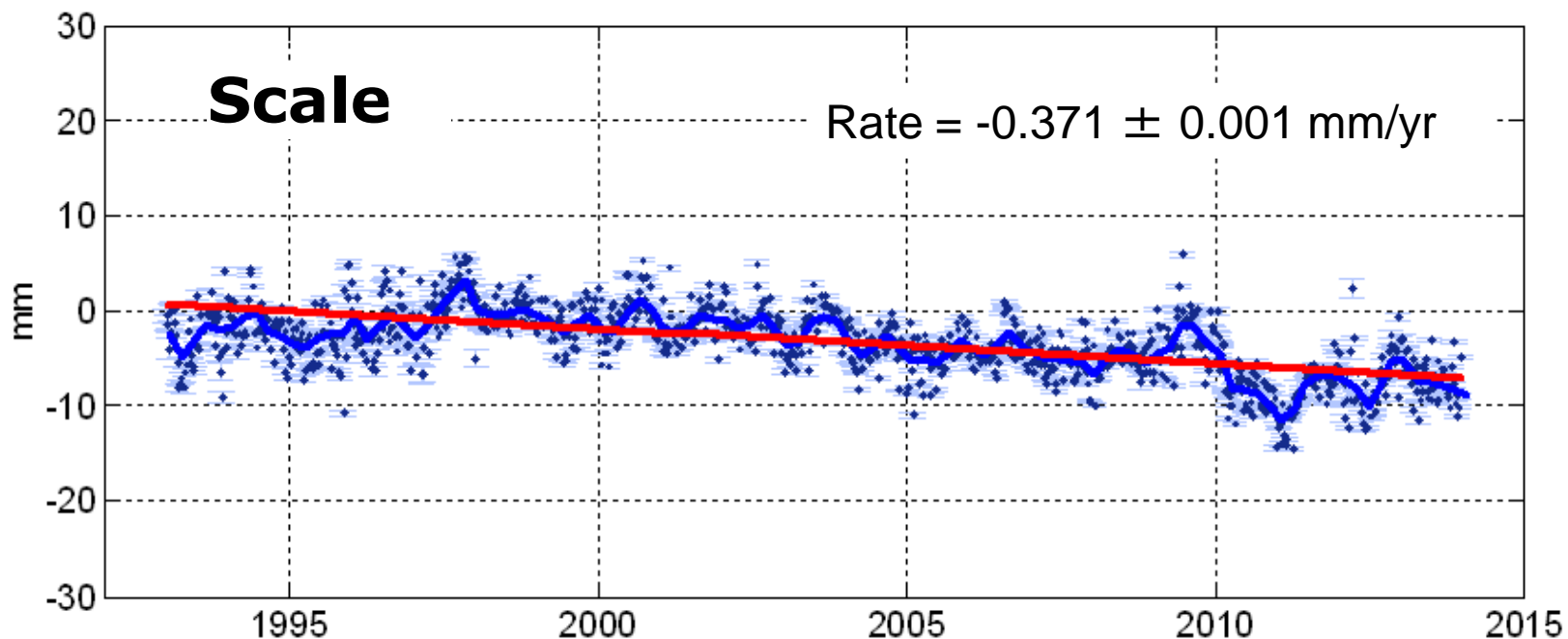



# International Earth Rotation Service

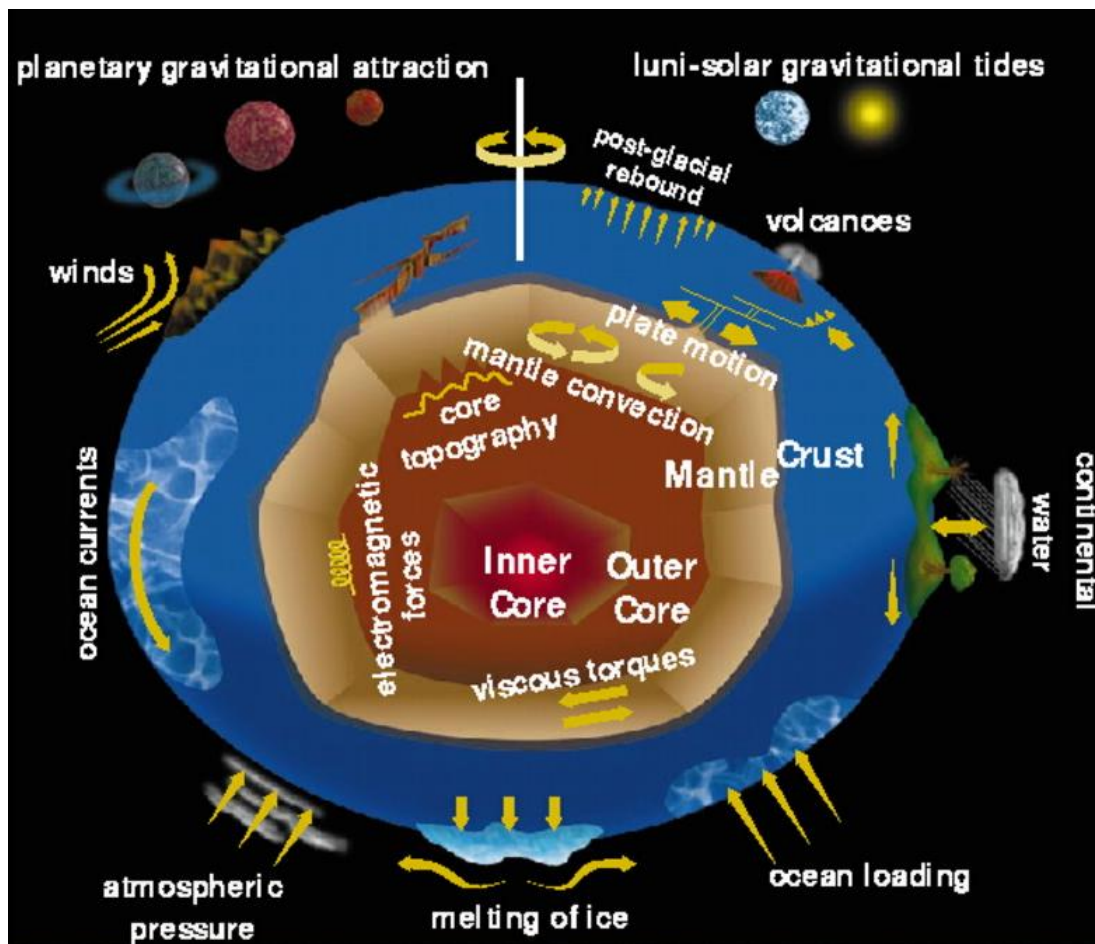

## Earth Orientation Parameters (EOP)

Polar motion (Chandler Wobble)

Length of Day (LOD)

High frequency Universal Time (UT1)

VLBI, working with distant quasars in the Celestial Reference Frame, is the only source of UT1, but SLR interpolated the wobble and LOD results between VLBI campaigns. These interpolations are now augmented by GNSS techniques.

The addition of relatively inexpensive GNSS networks (GPS, GLONASS, Galileo, etc.) and DORIS to the earlier SLR and VLBI networks over the past two decades has greatly densified the measurement of global tectonic plate motion and associated regional crustal deformation near plate boundaries.

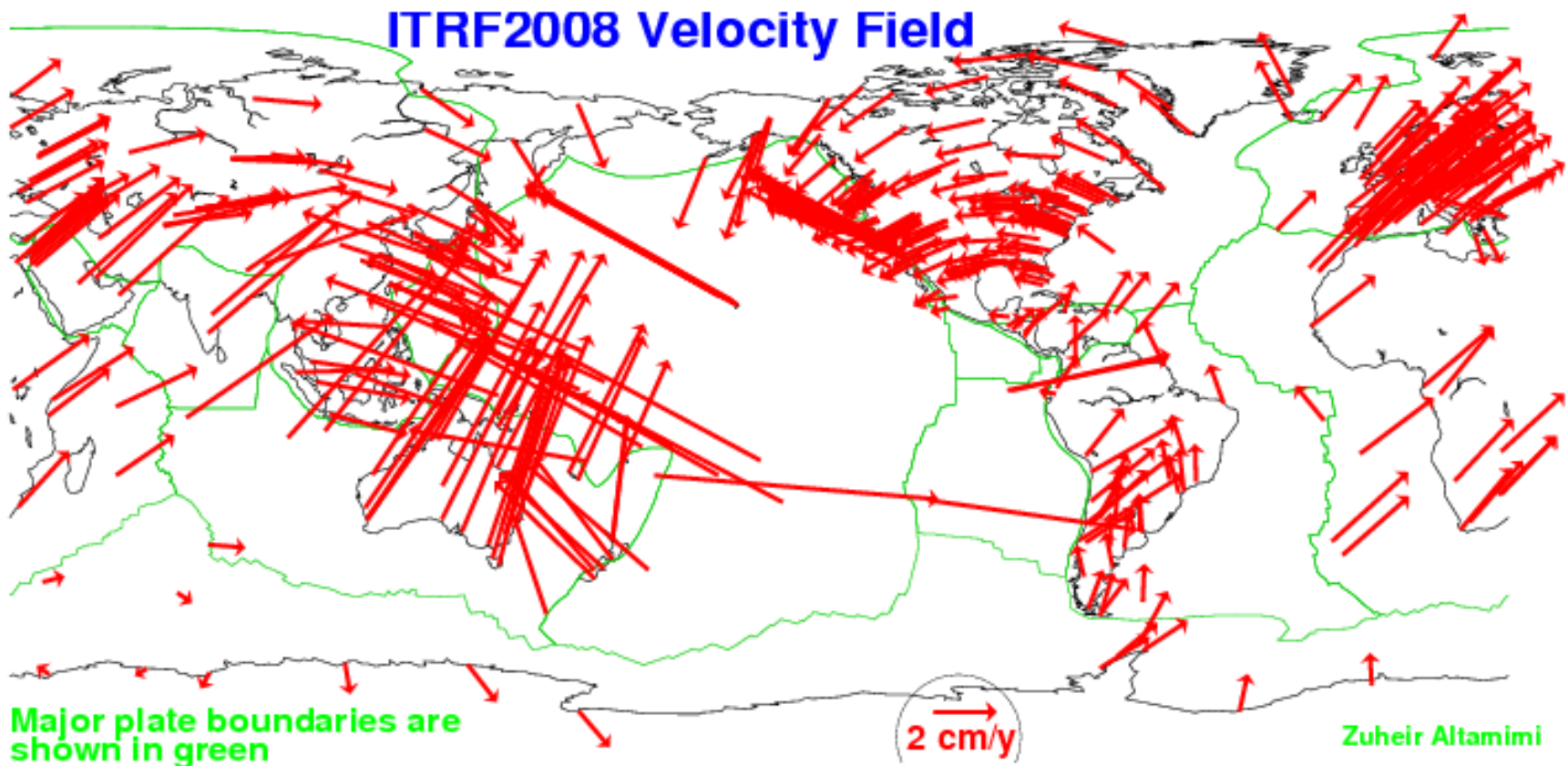





# EGM 96 Mean Gravity Anomalies\*



A **gravity anomaly** is the difference between the observed acceleration of a planet's gravity and a value predicted from a global model, expressed as a sum of spherical harmonics. A location with a positive anomaly exhibits more gravity than predicted, while a negative anomaly exhibits a lower value than predicted.

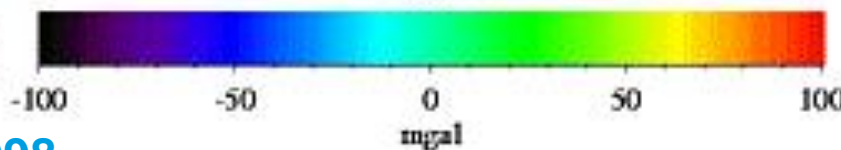
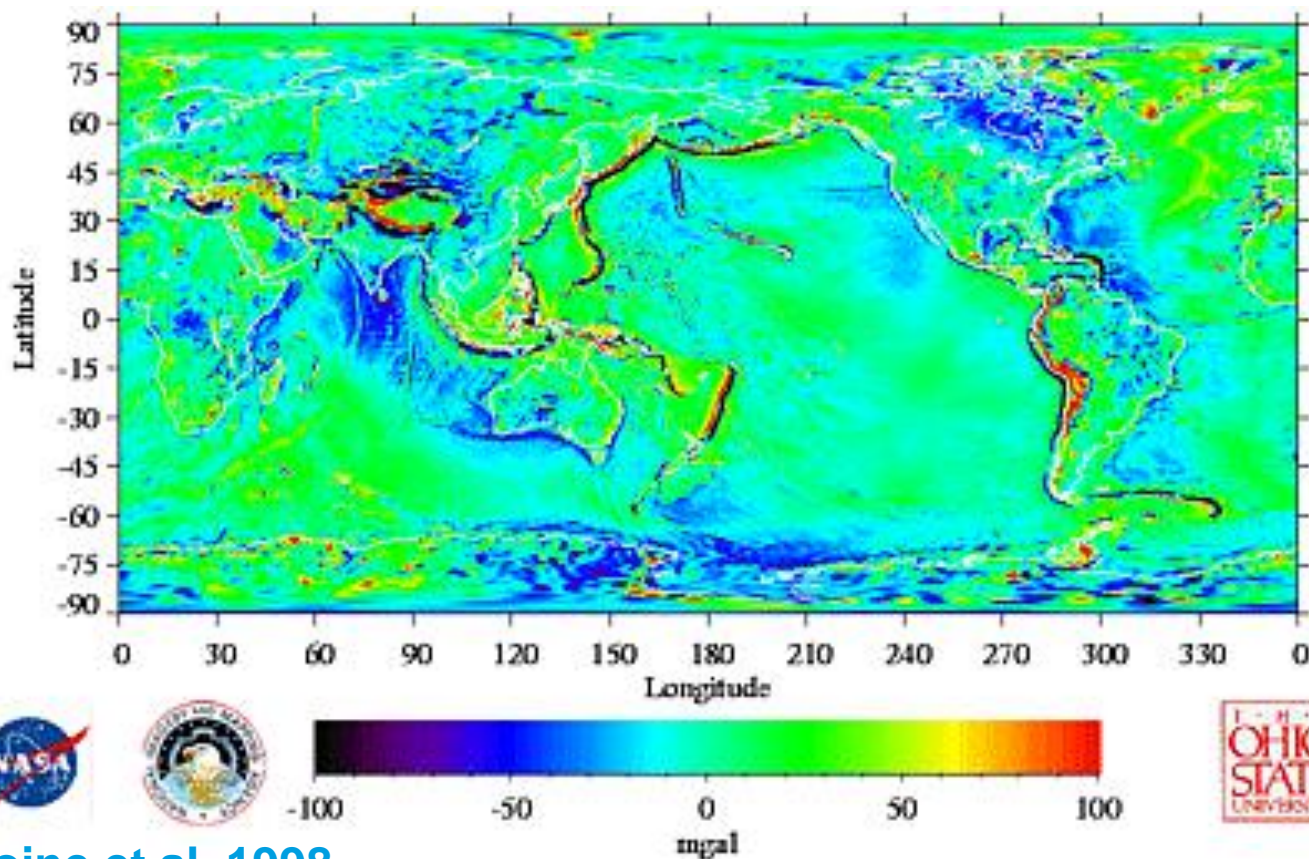

\*F. Lemoine et al, 1998





# JGM96 Earth Geoid



NGS Definition of “geoid”: “The equipotential surface of the Earth's gravity field which best fits, in a least squares sense, global mean sea level “

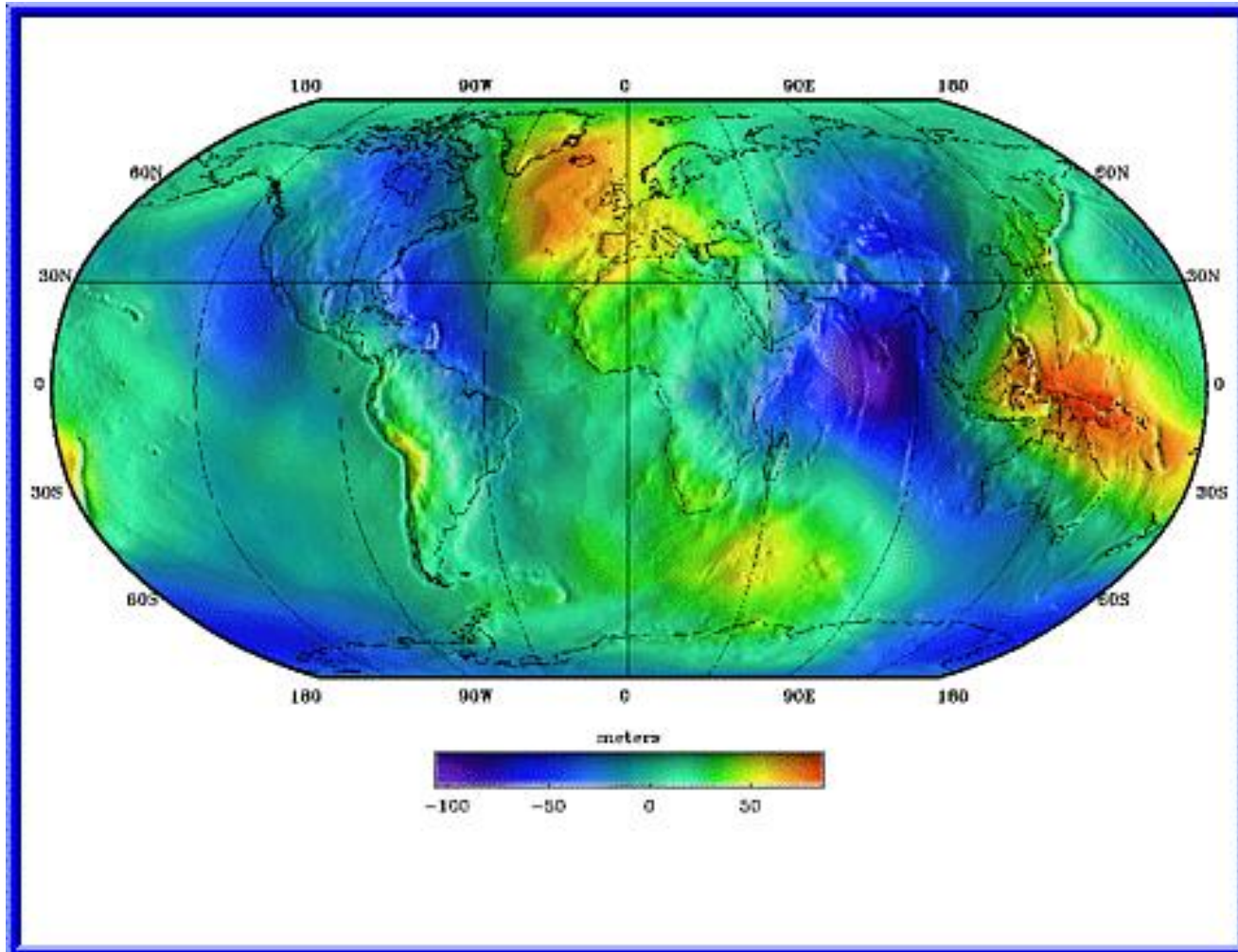

## GRACE (2002)

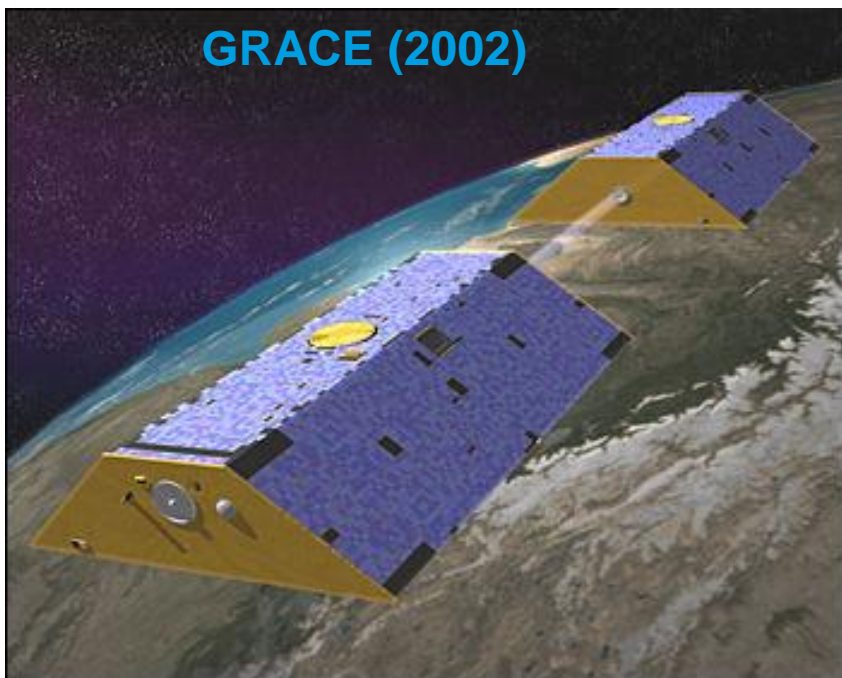

- Two identical spacecraft (GRACE A&B) in polar orbit at 500 km altitude are tracked by GPS and SLR
- Separation (~220 km) measured by K-band microwave link
- Observed changes to separation provide high spatial frequency components in the gravity field whereas SLR does a better job measuring low frequency components.

- Goals:
  - Map gravity field and changes with time
  - create a better profile of the Earth's atmosphere.
- The gravity variations that GRACE studies include:
  - changes due to surface and deep currents in the ocean
  - runoff and ground water storage on land masses
  - exchanges between ice sheets or glaciers and the oceans\*
  - variations of mass within the Earth.
- GRACE-2 will fly the same K-band microwave link with a potentially higher resolution laser –based satellite interferometer.

**Estimated Ice Mass Loss:**  
 100 Gigaton/yr in Antarctica  
 200 Gigaton/yr in Greenland



# Global Gravity Field from GRACE Mission

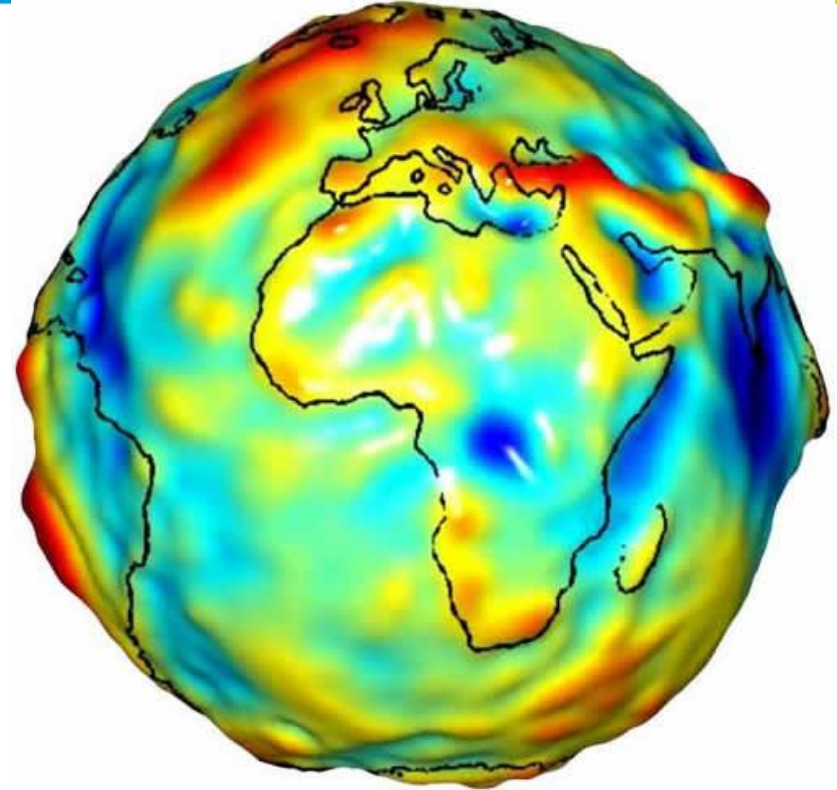
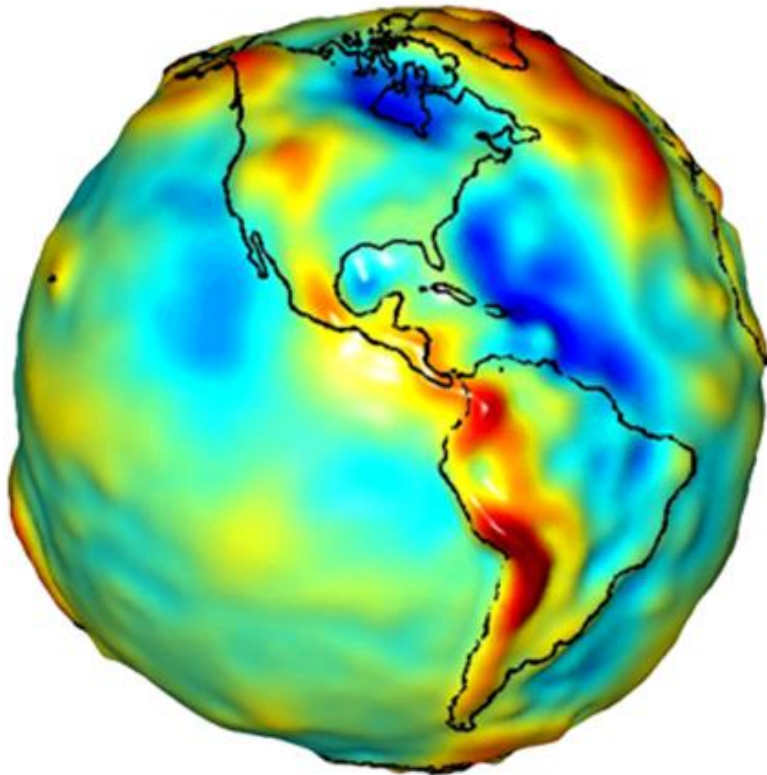

The images show the regions of strong (red, raised) and weak (blue, depressed) gravitational acceleration as measured by the GRACE mission. SLR is still the best source for the low order spherical harmonic coefficients.

A companion satellite with similar goals, the Gravity field and steady-state Ocean Circulation Explorer (GOCE) was launched by ESA on March 19, 2009





# Earth Oblateness Variations



$C_{2,0}$  is a coefficient for one of the lowest order terms in the spherical harmonic model of the Earth's gravity field which measures "roundness" or "oblateness". Until about the late 1990s, the increase in roundness was attributed to post-glacial rebound in Canada following the last ice age. However, as we approached the millennium, the direction of the coefficient changed sign which scientists attributed to the melting of ice due to global warming and redistribution of water mass.

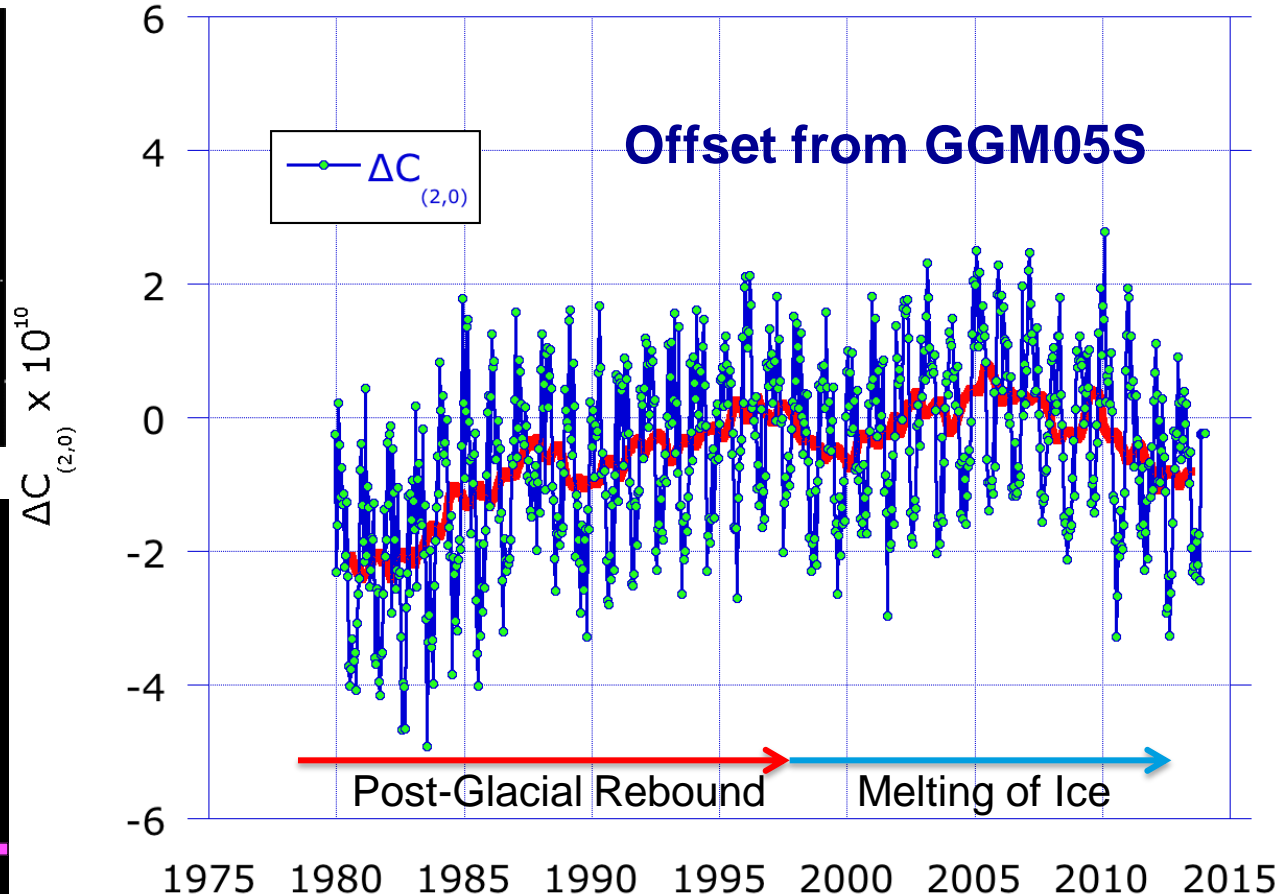
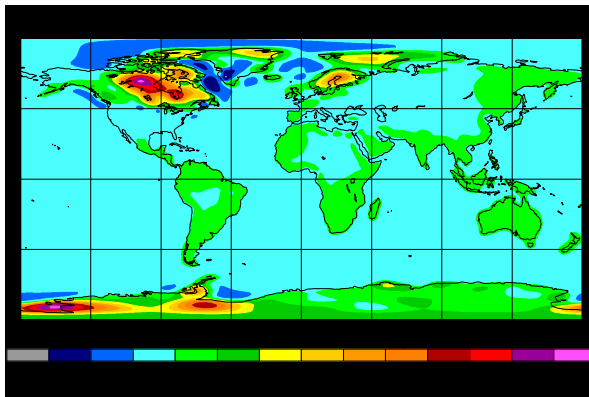
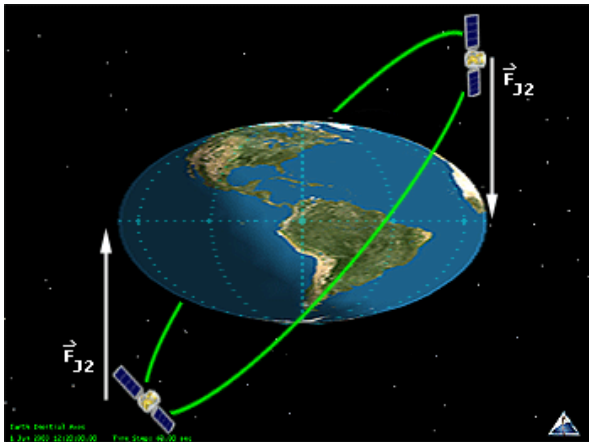





# C<sub>2,0</sub>: Comparison: SLR vs GRACE monthly

Courtesy: Frank Lemoine, NASA/GSFC

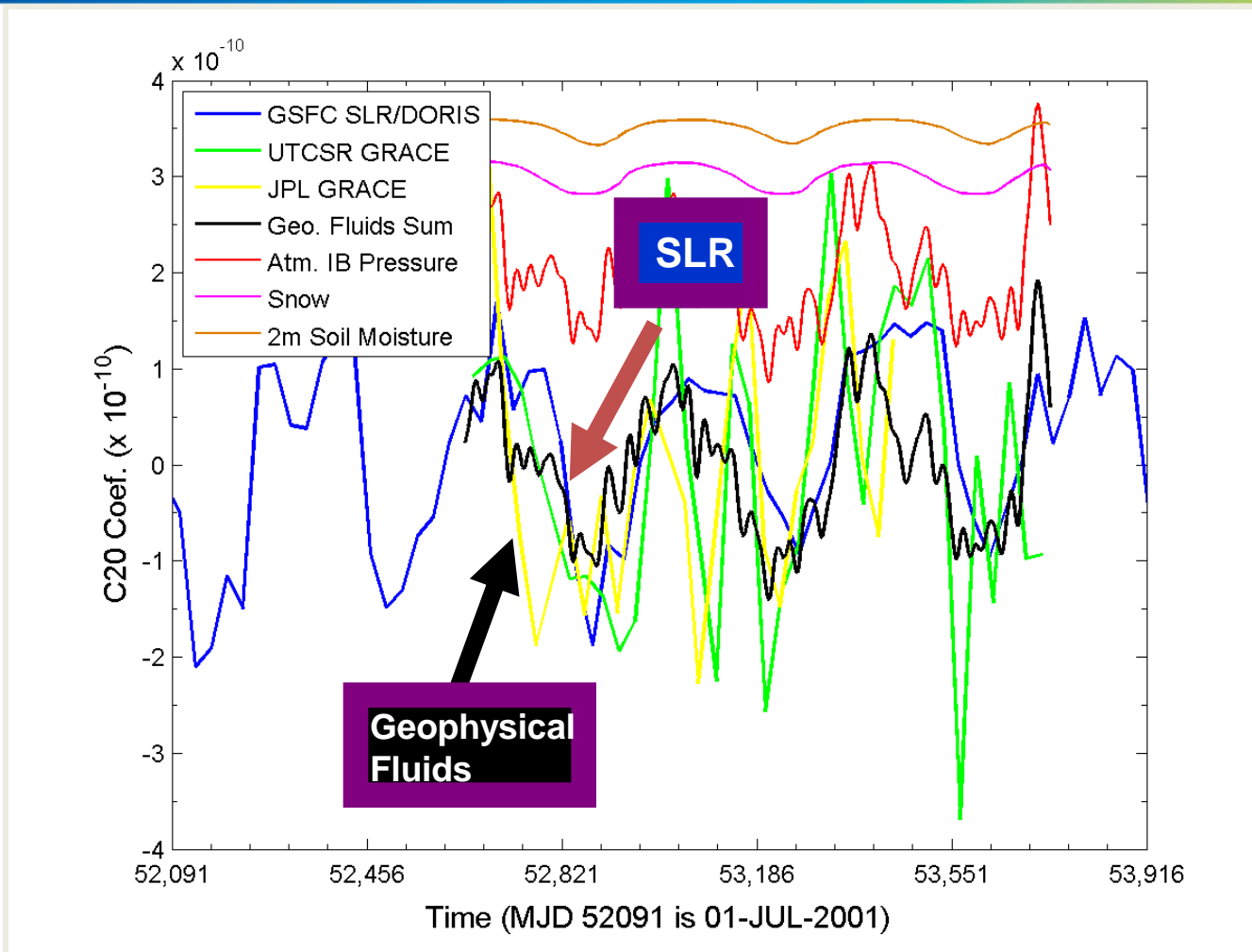

As our knowledge of the Earth gravity field improved, analysts were also able to better model non-conservative forces affecting satellite orbits, such as atmospheric drag and radiation pressures (Sun and Earth albedo).

## Radar altimetry on GeoSat, ERS-1, TOPEX/Poseidon, ERS-2, GFO, and JASON satellites, all tracked by SLR

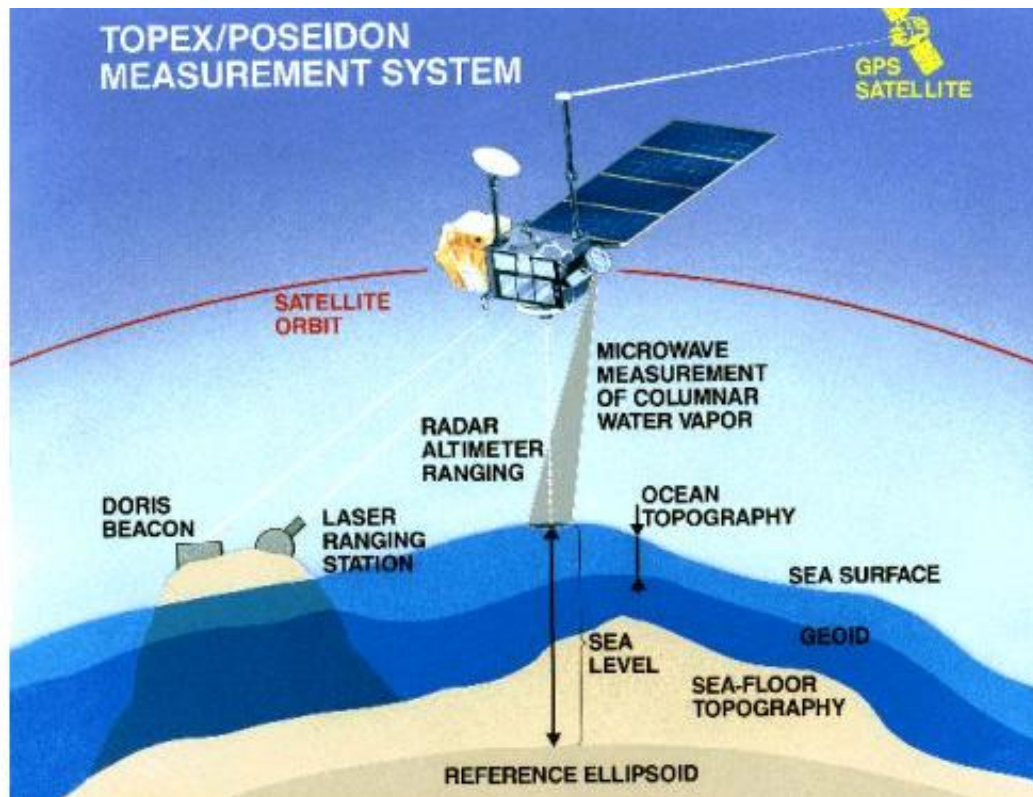

- “Ocean Topography” (OT) is defined as the height difference between the sea surface and the geoid (sum of gravity and Earth rotation effects)
- In the Northern hemisphere, currents flow CW around topographic highs and CCW around lows. The reverse is true in the Southern Hemisphere
- Height of the SST is proportional to the speed of the surface currents.
- Radar altimeter measures the distance between the sea surface and the spacecraft on a global scale
- SLR provides:
  - Cm accuracy SLR station locations relative to Geocenter
  - Moderate to long wavelength geoid surface relative to geocenter
  - Cm accuracy positioning of the TOPEX/Poseidon satellite in geocentric reference frame

$$OT = \text{Satellite Distance from Geocenter (SLR)} - \text{Local Geoid (SLR/Alt)} - \text{Altimeter Range}$$



# Global Mean Sea Level (MSL)



Courtesy: NASA Measures Project\*

\*[http://podaac.jpl.nasa.gov/Integrated\\_MultiMission\\_Ocean\\_AltimeterData](http://podaac.jpl.nasa.gov/Integrated_MultiMission_Ocean_AltimeterData)

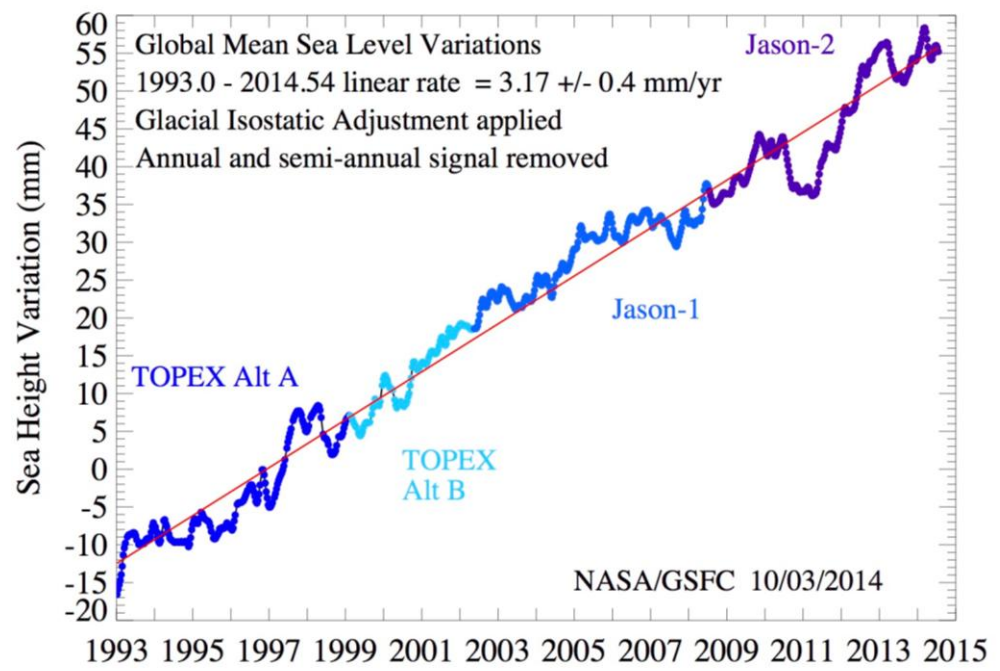

(Topex/Poseidon, Jason-1, and Jason-2 –1992 through 2014)

**70 mm rise in Mean Sea Level from 1992 to 2014 (22 years) yields rate of 3.17 ± 0.4 mm/yr**

## Contributors to Sea Level Change

- variations in sea water temperature and salinity at all depths
- Tectonic changes to the water basin “shape”
- change of the ocean mass as a result of exchanges of water with the other surface reservoirs (atmosphere, continental waters, glaciers and ice sheets).

## Tide Gauge Drawbacks

- Prior to the launch of the oceanographic satellites, tide gauges were used to estimate sea level rise
- geographical distribution provides very poor sampling of the ocean basins,
- measure sea level relative to the land, hence recording vertical crustal motions that may be of the same order of magnitude as the sea level variation.



# Spatially Resolved Global Sea Level Rise

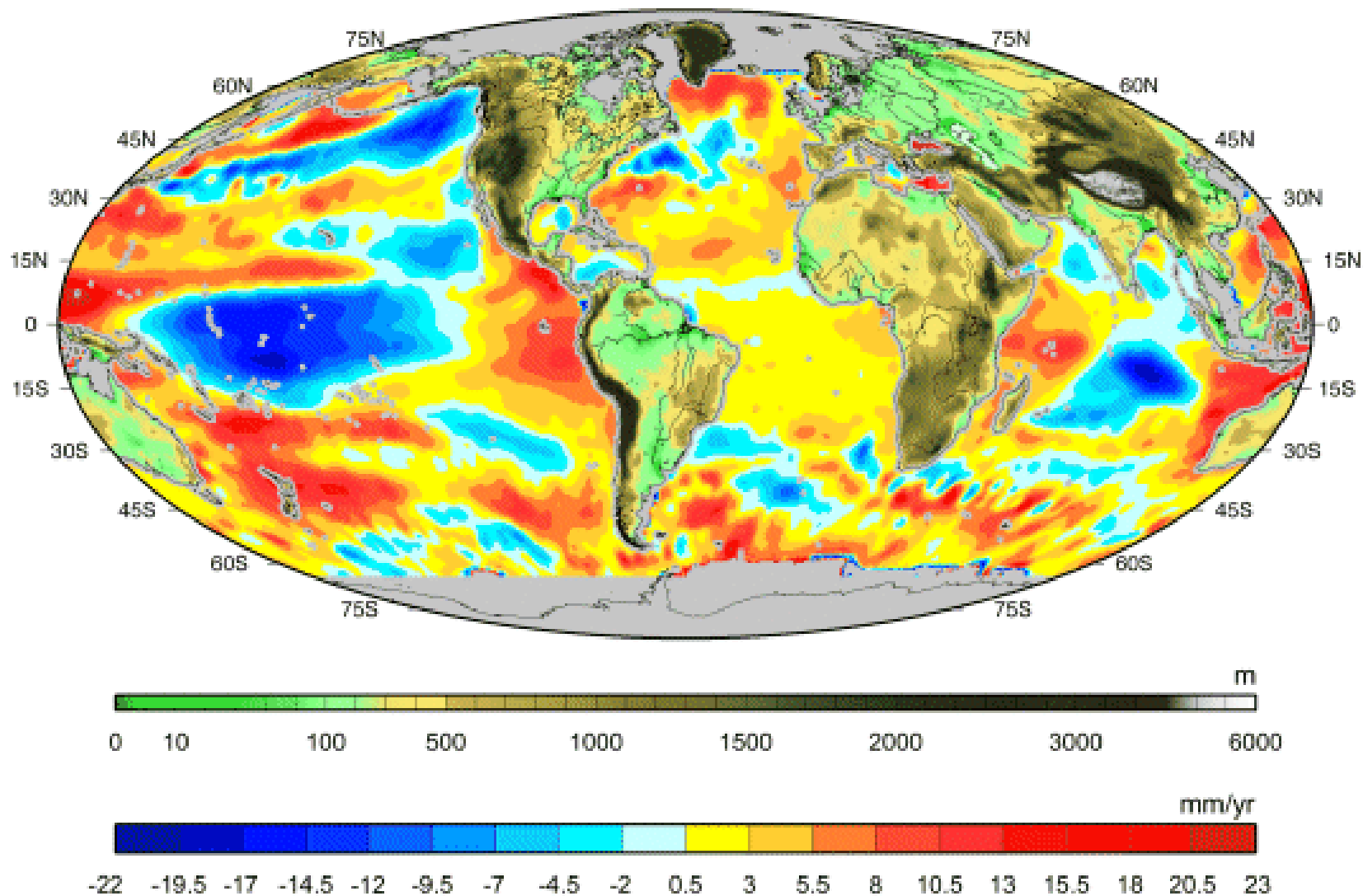



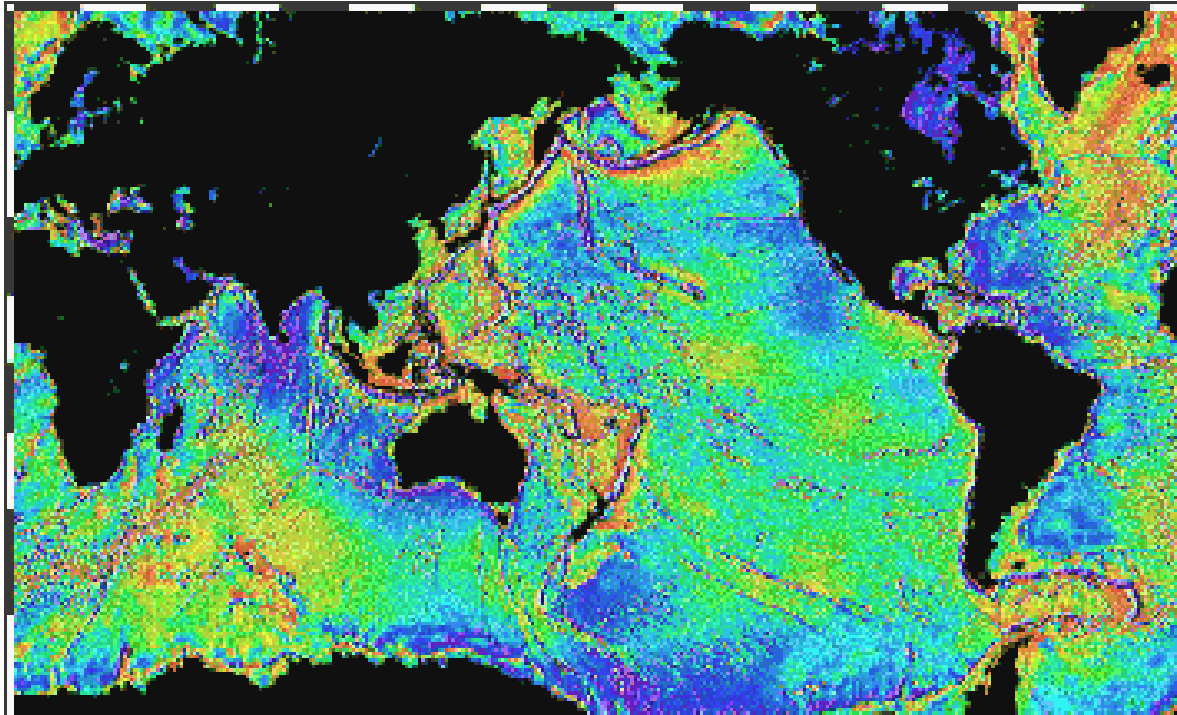

Ocean floor topography from Geosat and ERS-1 radar altimetry obtained with SLR tracking only  
(David Sandwell and Walter Smith)

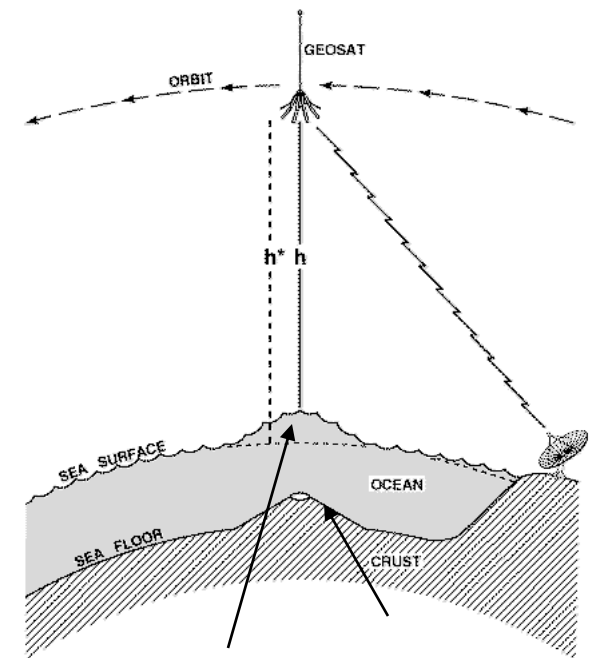

Approximately 1000:1  
ratio in heights  
(1 km sea mount creates  
~1 m bump in sea level)



# Lunar Laser Ranging



MLRS ranging to the Moon

- **Currently five passive retroreflector arrays were landed on the Moon by**
  - 3 NASA manned Apollo missions (11,14, and 15)
  - 2 Soviet Lunakhod missions (1 and 2)
- **For over 30 years, the LLR data set was provided by three sites:**
  - MLRS, McDonald Observatory, Texas, USA
  - CERGA LLR, Grasse, France
  - Mt. Haleakala, Hawaii, USA (decommissioned in 1992)
- **New LLR systems have since come online:**
  - MLRO, Matera, Italy
  - Apollo, Apache Point, New Mexico, USA (multiphoton, 3.5 m telescope)



# LLR Range Precision vs Time

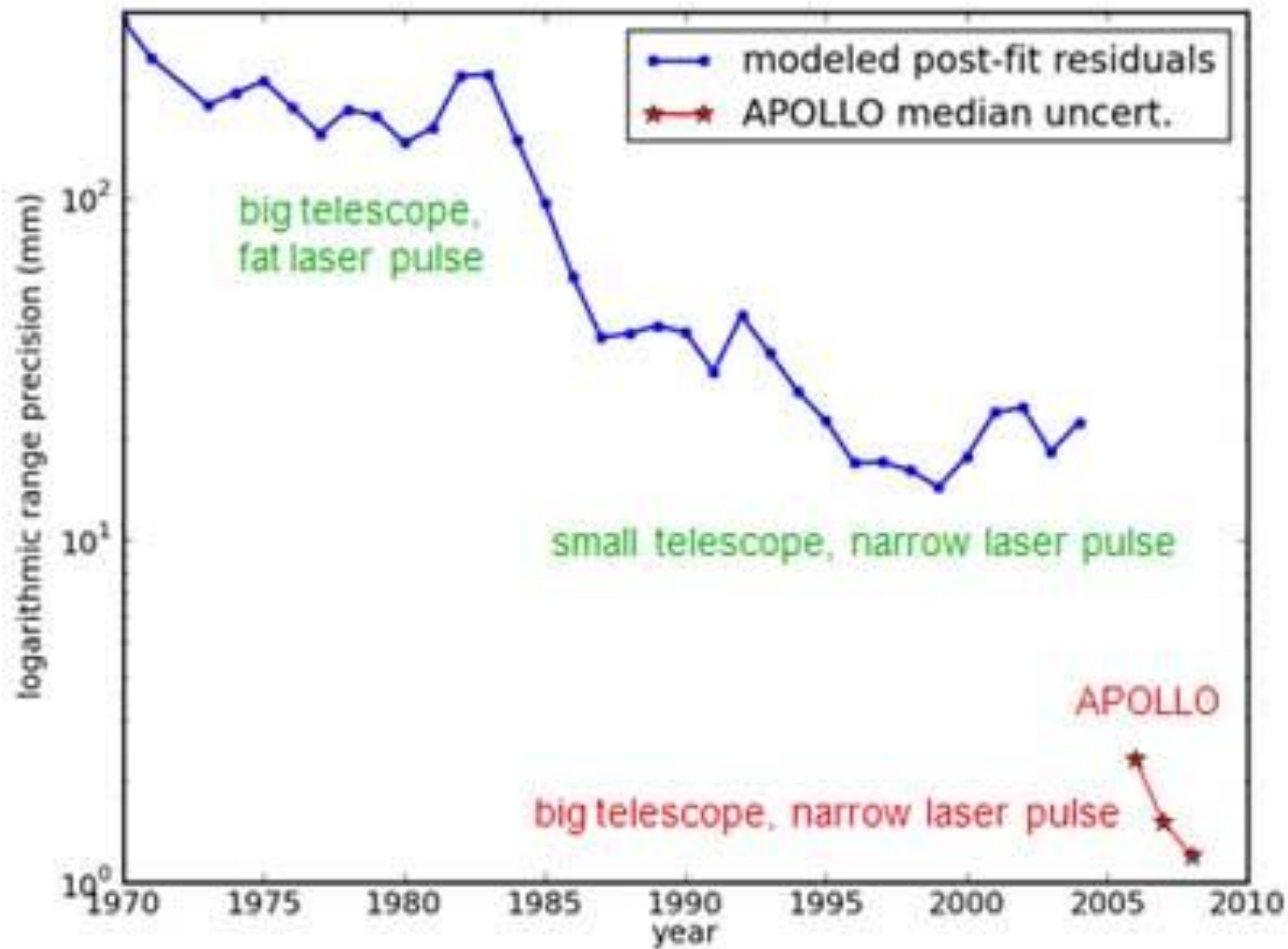



# Some LLR Applications



- **Lunar Physics (LLR)**
  - Centimeter accuracy lunar ephemerides
  - Lunar librations (variations from uniform rotation)
  - Lunar tidal displacements
  - Lunar mass distribution
  - Secular deceleration due to tidal dissipation in Earth's oceans
  - Measurement of  $G(M_E + M_M)$
- **Solar System Reference Frame (LLR)**
  - Dynamic equinox
  - Obliquity of the Ecliptic
  - Precession constant
- **General Relativity/Fundamental Physics**
  - Test/evaluate competing gravitational and relativistic theories
  - LLR validates Strong Equivalence Principle (SEP), which states that an object's movement in a gravitational field does not depend on its mass or composition.
  - Constrain  $\beta$  parameter in the Robertson-Walker Metric
  - Constrain time rate of change in  $G$  ( $G\text{-dot}$ )



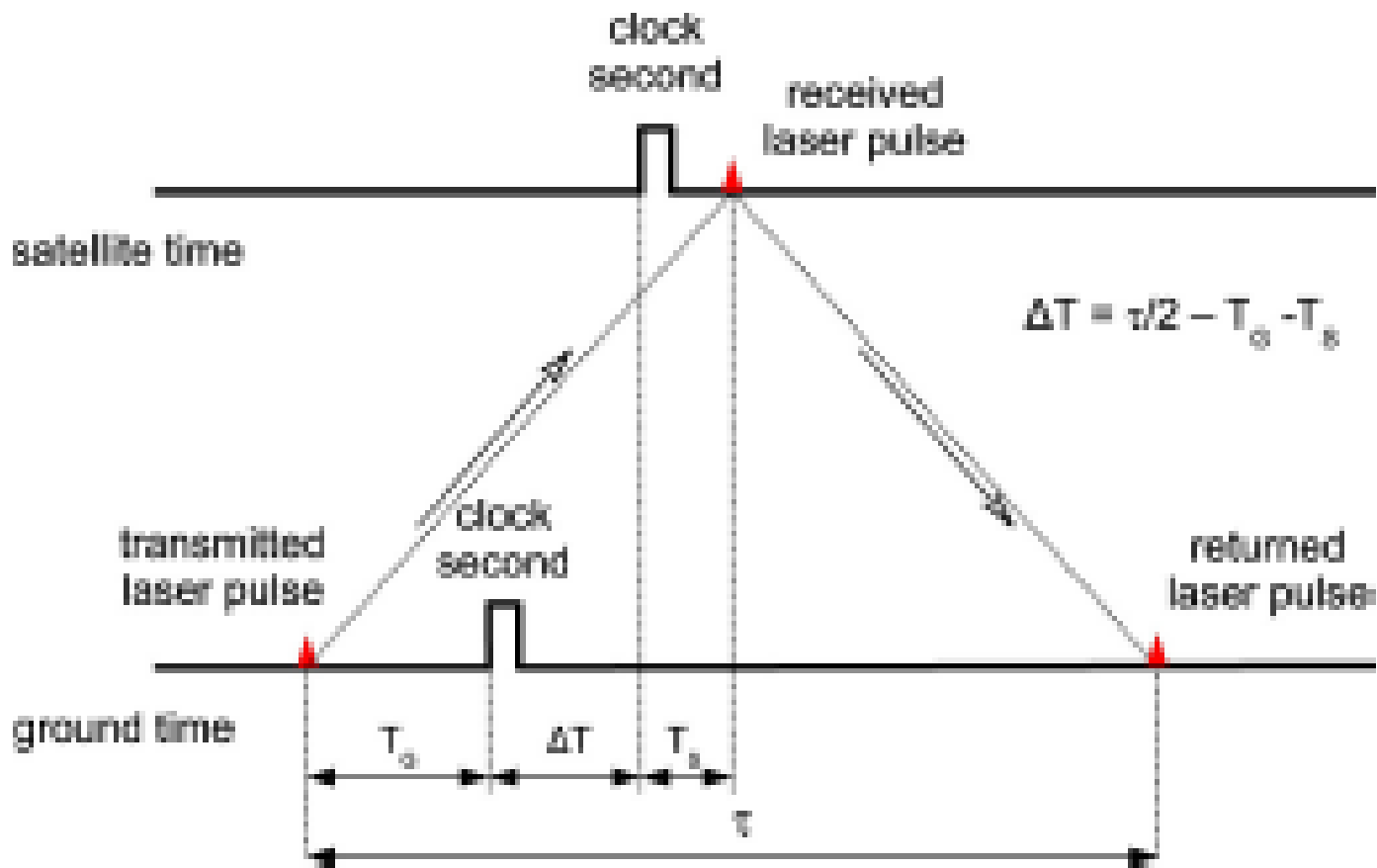

The pulse time of arrival at the satellite coincides with the midpoint of the recorded ground start and stop times which allows one to compute the offset  $\Delta T$  between the two clocks. If a second ground station performs the same experiment to the satellite, the time offset between the two ground clocks can be determined. Global laser time transfer experiments include L2T2 (France), Compass (China), ELT/ACES (ESA), SOTA (Japan).



# Univ. of Maryland Airborne Atomic Clock Experiment (C. O. Alley et al, 1975)

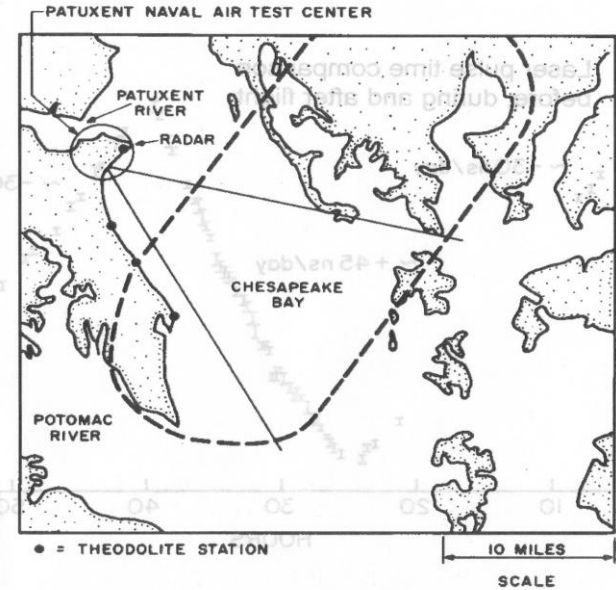
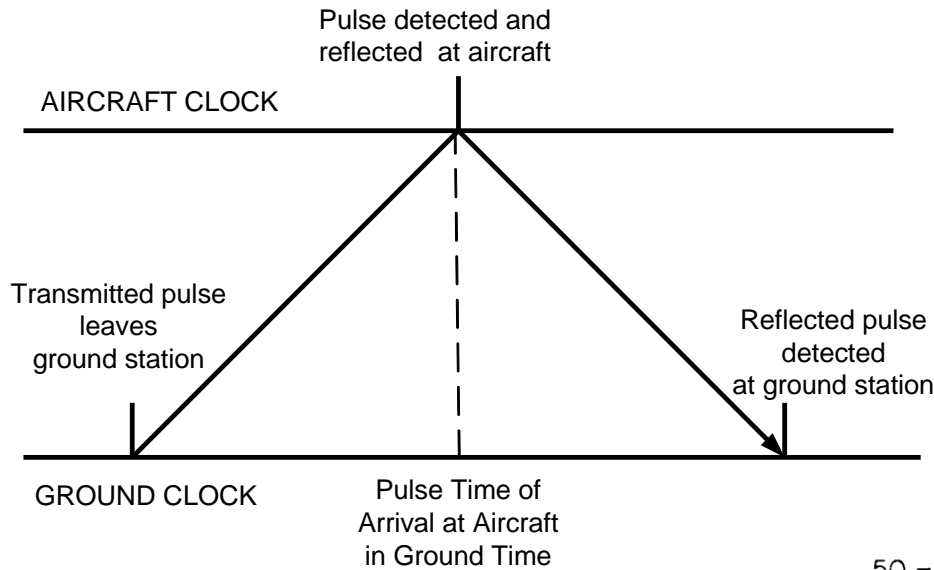

**Gravitational redshift**      **52.8 ns**  
**Time dilation**              **-5.7 ns**  
**Net effect**                    **47.1 ns**

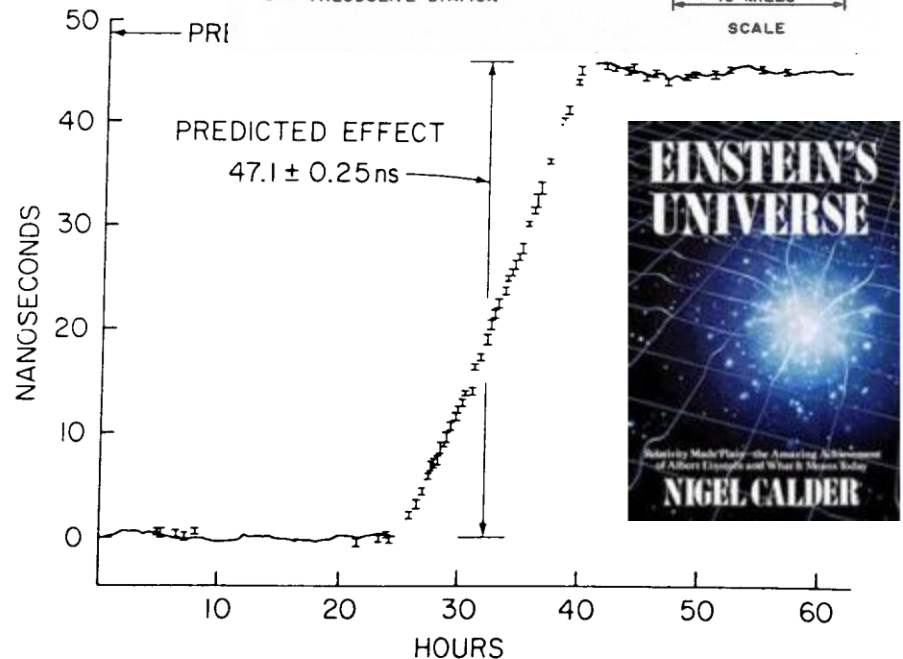



# World's Most Expensive Altimeter

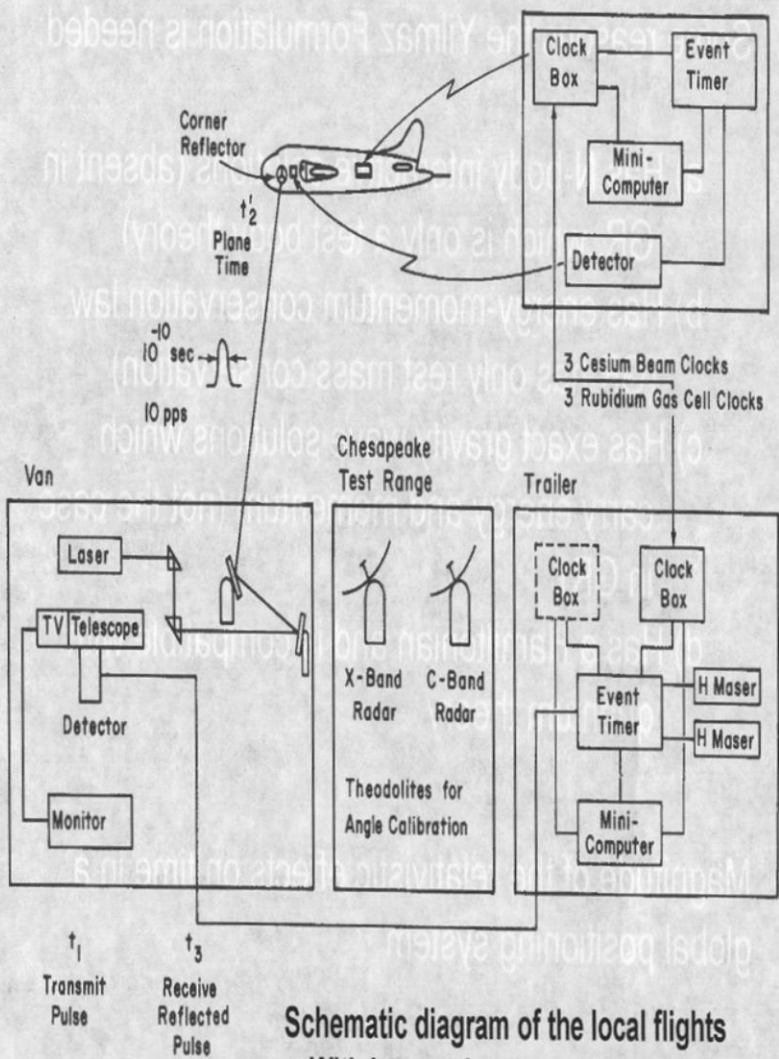

Schematic diagram of the local flights  
With laser pulse time comparison

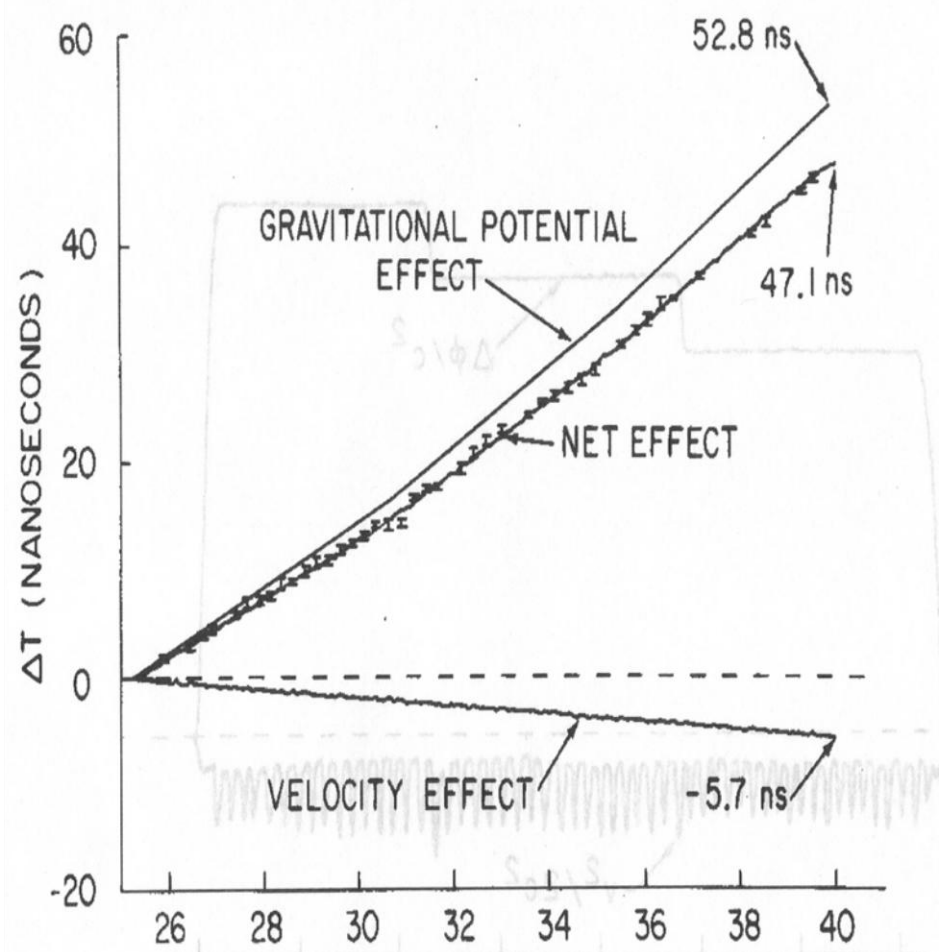

## Laser Time Transfer—operational space missions

CTU SPAD photon counters on-board of 5 satellites



### China

- Compass (Beidou-2) M1
- Compass IGSO-1
- Compass IGSO-3
- Compass M3



T2L2

### CNES-NASA

Jason-2, 20. 6. 2008

~100 psec  
absolute time  
transfer

LTT package

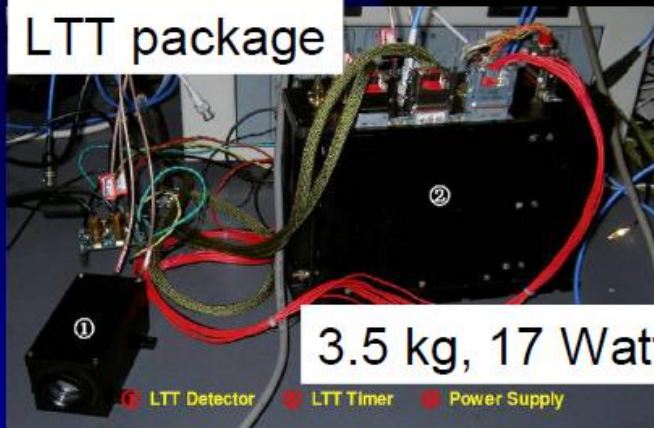

3.5 kg, 17 Watts

① LTT Detector    ② LTT Timer    ③ Power Supply

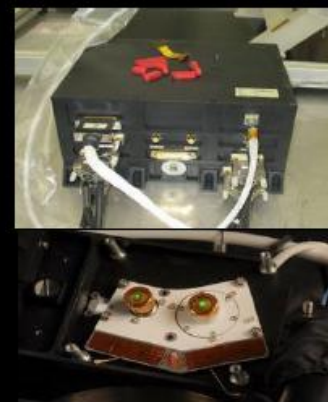





# European Laser Timing (ELT) Experiment

Courtesy: Ivan Prochazka, Czech Republic



## Laser time transfer ground to space, ESA European Laser Timing ELT, proposed by Procházka & Schreiber, exp. 2016



- Atomic Clock Ensemble in Space (ACES)  
Includes Cs Fountain Clock and H-Maser
- Simultaneous SLR and laser time transfer to International Space Station, Columbus module
- Precision 3 ps @ 100 s, accuracy < 25 ps (ground tested)
- Photon counting detector by CTU



Detector assembly at CTU in Prague

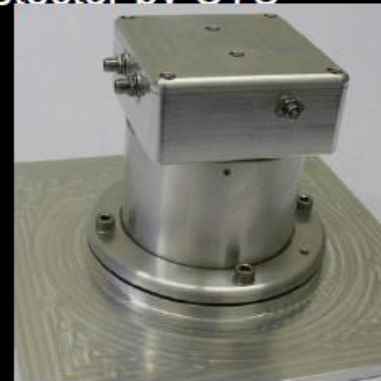

Detector package Engineering Model



# One Way Transponder (e.g. LRO)

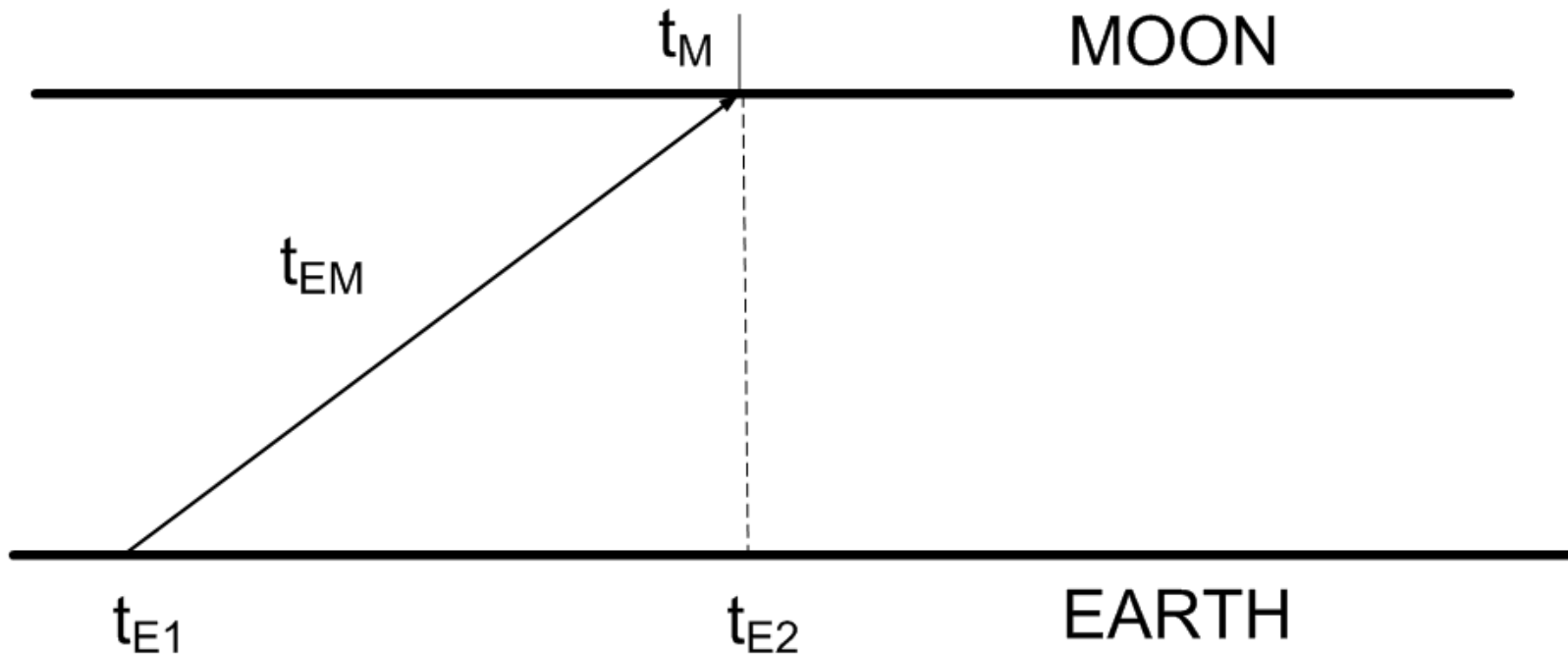

Actual Range  $R = c(t_{E2} - t_{E1})$

Measured Range  $R_m = c(t_M - t_{E1})$

Range Error  $\Delta R = R_m - R = c(t_M - t_{E2}) = c\Delta t$

One-way ranging requires good synchronization between the Earth and spaceborne clocks  
( $\Delta t = 33$  psec for 1 cm ranging)



# Laser Transponders: Laser Ranging Beyond the Moon



- Given the current difficulty of laser ranging to passive reflectors on the Moon, conventional single-ended ranging to passive reflectors at the planets is unrealistic due to the  $R^{-4}$  signal loss.
- Since double-ended laser transponders have active transmitters on both ends of the link, signal strength falls off only as  $R^{-2}$  and precise interplanetary ranging and time transfer is possible.



# Types of Transponders\*

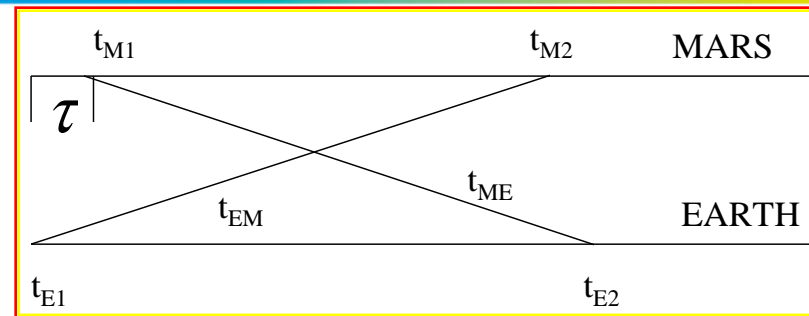
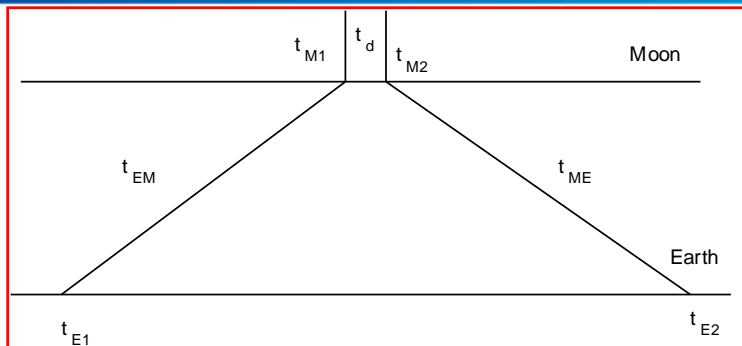

- **Echo Transponders ( $R \ll 1$  AU)**

- Spacecraft transponder detects pulses from Earth and fires a reply pulse back to the Earth station.
- To determine range, the delay  $t_d$  must be known a priori (or measured onboard and communicated back to Earth) and subtracted from the measured round-trip time-of-flight at the Earth station.
- Works well on “short” links (e.g. to the Moon) where the round trip transit time is short and the single shot detection probability at both terminals is high.

- **Asynchronous Transponders ( $R > 1$  AU)**

- Transmitters at opposite terminals fire asynchronously (independently).
- Signal from the opposite terminal must be acquired autonomously via a search in both space and time (easier when terminals are on the surface or in orbit about the planet)
- The spacecraft transponder measures both the local transmitter time of fire and any receive “events” (signal plus noise) on its own time scale and transmits the information back to the Earth terminal via the spacecraft communications link. Range and clock offsets are then computed.
- This approach works well on “long” links (e.g., interplanetary) even when the single shot probability of detection is relatively small

\*J. Degnan, J. Geodynamics, 34, pp. 551-594 (2002).





# Asynchronous Ranging and Time Transfer\*

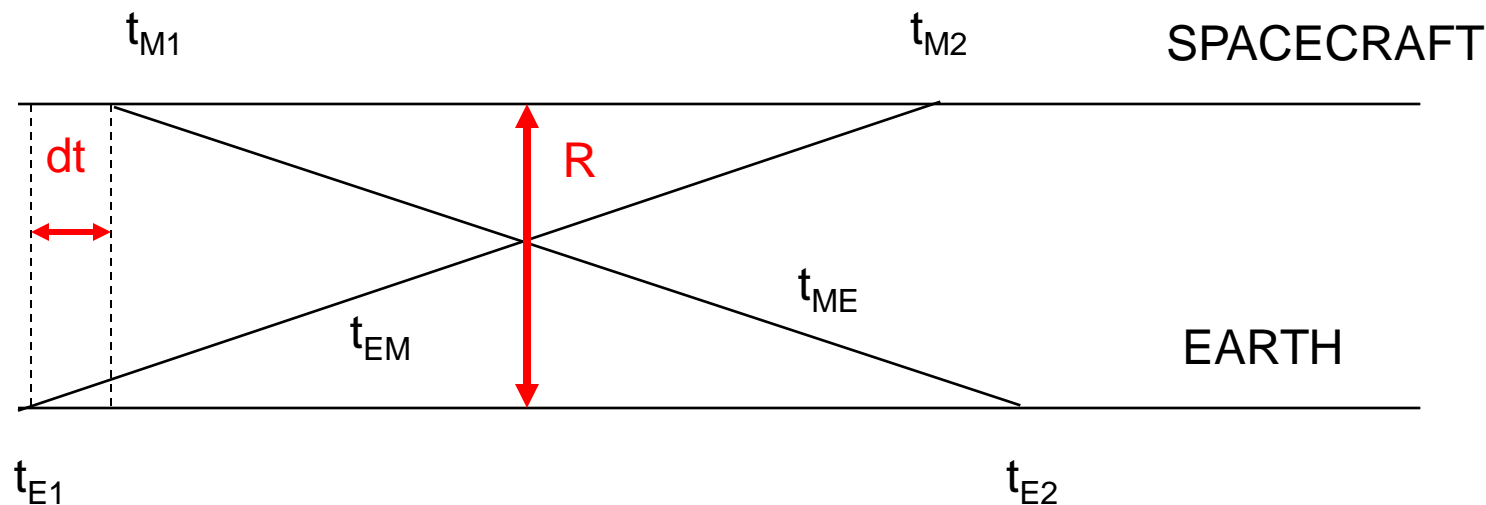

Range  $R = c(t_{ME} + t_{EM})/2 = c [(t_{E2} - t_{E1}) + (t_{M2} - t_{M1})]/2$

Clock Offset  $dt = [(t_{E2} - t_{E1}) - (t_{M2} - t_{M1})]/[2(1 + R/c)]$

\*J. Degnan, J. Geodynamics, 34, pp. 551-594 (2002).



# Some Transponder Applications



- **Solar System Science**

- Solar Physics: gravity field, internal mass distribution and rotation
- Few mm accuracy lunar ephemerides and librations
  - Improves ranging accuracy and temporal sampling over current lunar laser ranging (LLR) operations to Apollo retroreflectors on the Moon with small, low energy, ground stations
- Decimeter to mm accuracy planetary ephemerides
- Mass distribution within the asteroid belt

- **General Relativity**

- Provides more accurate (2 to 3 orders of magnitude) tests of relativity and constraints on its metrics than LLR or microwave radar ranging to the planets, e.g.
  - Precession of Mercury's perihelion
  - Constraints on the magnitude of  $G\text{-dot}$  ( $1 \times 10^{-12}$  from LLR)
  - Gravitational and velocity effects on spacecraft clocks
  - Shapiro Time Delay

- **Lunar and Planetary Mission Operations**

- Decimeter to mm accuracy spacecraft ranging
- Calibration/validation/backup for Deep Space Network (DSN) microwave tracking
- Subnanosecond transfer of GPS time to interplanetary spacecraft for improved synchronization of Earth/spacecraft operations
- Transponder is a pathfinder technology for interplanetary optical communications and can serve as an independent self-locking beacon for collocated laser communications systems



# Laser vs Microwave Transponders



- **Laser Advantages**

- Ranging/timing instrumentation is more precise ( $\sim 1$  mm) due to availability of picosecond transmitters, detectors, and timers in the optical regime
- Divergence of transmitted optical beam is 4-5 orders of magnitude smaller than microwaves for a given transmit aperture ( $\sim \lambda/D$ )
  - More energy focused at the opposite receiver
  - Smaller antennas (telescopes) and transmitters, more lightweight, less prime power
- Charged particles cannot follow optical frequencies so
  - no propagation delays due to Earth's ionosphere or the interplanetary solar plasma
  - no need for solar plasma models or correction via dual wavelength methods
- Optical atmospheric propagation delay uncertainties are typically at the sub-cm level with ground measurements of pressure, temperature, and relative humidity, as in SLR.

- **Laser Disadvantages**

- Requires more precise pointing knowledge and control (but well within SOA )
- Link availability affected by weather and clouds but can be  $> 99\%$  via several globally distributed ground sites or three orbiting terminals
- As with any new technology, lasers have not yet demonstrated space heritage, lifetime and reliability comparable to more mature microwave transponders but several laser altimeters have already operated in Earth, Lunar, Mars, and Mercury orbits.



# Two-Way Transponder Experiment to the Messenger Spacecraft (May/June 2005)\*



**GSFC 1.2 Meter Telescope**

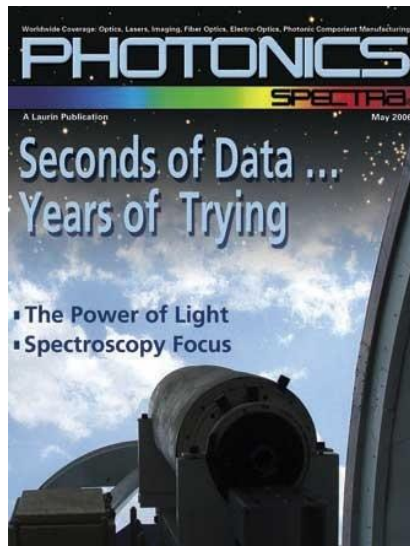

**Messenger Laser Altimeter (MLA) enroute to Mercury**



**24.3 Million Km**

## Ground Station

Xiaoli Sun      Jan McGarry  
Tom Zagwodzki   John Degnan  
D. Barry Coyle

## Science/Analysis/Spacecraft

David Smith      Maria Zuber  
Greg Neumann   John Cavanaugh

\*D. E. Smith et al, *Science*, January 2006.



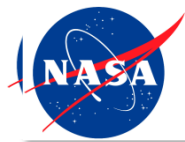

# One-Way Earth-to-Mars Laser Transponder Experiment (Sept. 2005)

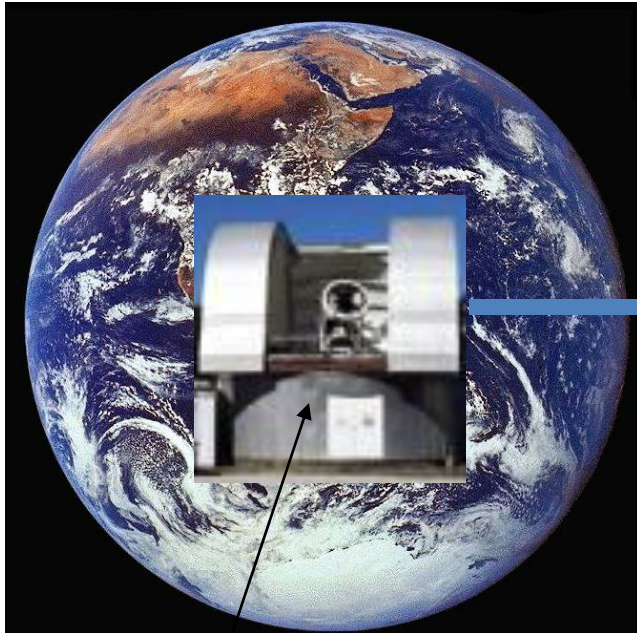

80 Million Km!

~500 pulses  
observed at Mars!

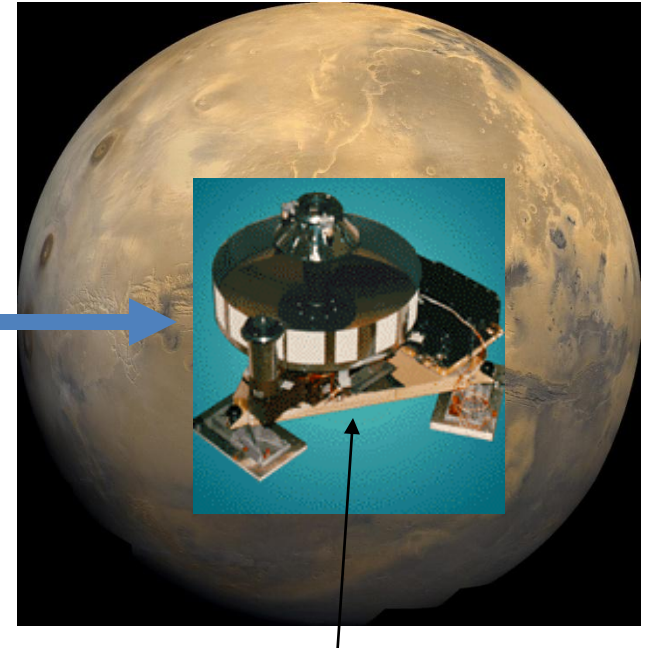

## GSFC 1.2 Meter Telescope

### Ground Station

Xiaoli Sun            Jan McGarry  
Tom Zagwodzki    John Degnan

## MOLA at Mars

### Science/Analysis/Spacecraft

David Smith            Maria Zuber  
Greg Neumann        Jim Abshire



# Transponder Link Parameters\*



Experiment	MLA (cruise)		MOLA (Mars)
Range ( $10^6$ km)	24.3		~80.0
Wavelength, nm	1064		1064
	Uplink	Downlink	Uplink
Pulsewidth, nsec	10	6	5
Pulse Energy, mJ	16	20	150
Repetition Rate, Hz	240	8	56
Laser Power, W	3.84	0.16	8.4
Full Divergence, $\mu$ rad	60	100	50
Receive Area, $m^2$	.042	1.003	0.196
EA-Product, $J\cdot m^2$	0.00067	0.020	.0294
PA-Product, $W\cdot m^2$	0.161	0.160	1.64

**Table 1: Summary of key instrument parameters for recent deep space transponder experiments at 1064 nm.**

\*J. Degnan, Int. J. Modern Physics D, 16, pp. 1-14 (2007).



# The Road Forward



- **Messenger and MOLA were experiments of opportunity rather than design.**
  - Since the spacecraft had no ability to lock onto the opposite terminal or even the Earth image, the spaceborne lasers and receiver FOV's were scanned across the Earth terminal providing only a few seconds of data.
  - Detection thresholds were relatively high due to the choice of wavelength (1064 nm) and the use of analog multiphoton detectors
  - Precision was limited to roughly a decimeter or two by 2<sup>nd</sup> generation SLR technology, i.e. 6 nsec laser pulsewidths and comparable receiver bandwidths.
- **The physical size, weight, and accuracy of future interplanetary transponder and laser communications experiments will benefit from current SLR photon counting technology, such as:**
  - Multi-kHz, low energy, ultrashort pulse lasers (10 to 50 psec)
  - Single photon sensitivity, picosecond resolution, photon-counting receivers
  - Autonomous tracking with transmitter point ahead and receiver pointing correction via photon-counting multi-anode detectors.
- **The SLR satellite constellation can accurately mimic interplanetary links (including the Earth's atmosphere). for inexpensive, pre-mission testing of both laser transponder and communications concepts.**

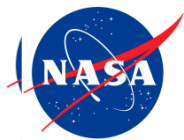

# Simulating Interplanetary Laser Ranging and Communications using the SLR Constellation\*



\*J. Degnan, Int. J. Modern Physics D, 16, pp. 1-14 (2007).

## Link Equations (A to B)

Transponder/Lasercom System:

$$n_T^{AB} = \frac{4\eta_q^B \eta_t^A \eta_r^B T_A^{\sec\theta_A} T_B^{\sec\theta_B}}{h\nu_A (\theta_t^A)^2 (4\pi)} \frac{E_t^A A_r^B}{R_T^2}$$

One/Two-Station Ranging to a Satellite:

$$n_R^{AB} = \frac{4\eta_q^B \eta_t^A \sigma_s \eta_r^B T_A^{2\sec\theta_A}}{h\nu_A (\theta_t^A)^2 (4\pi)^2} \frac{E_t^A A_r^B}{R_R^4}$$

Setting  $n_T^{AB} = n_R^{AB}$  gives us an equivalent transponder range for the two-station SLR experiment

$$R_T(h, \theta_A, \sigma_s) = R_R^2(h, \theta_A) \sqrt{\frac{4\pi}{\sigma_s} \left( \frac{T_B^{\sec\theta_B}}{T_A^{\sec\theta_A}} \right)}$$

$$\cong R_R^2(h, \theta_A) \sqrt{\frac{4\pi}{\sigma_s} \frac{1}{T_A^{\sec\theta_A}}}$$

**Simulations can be carried out from a single SLR station (e.g. Wettzell) or two adjacent stations (e.g. GSFC 1.2 m and NGSLR) located within the far field pattern of the retroreflector array.**





# Planet/Satellite Equivalence\*

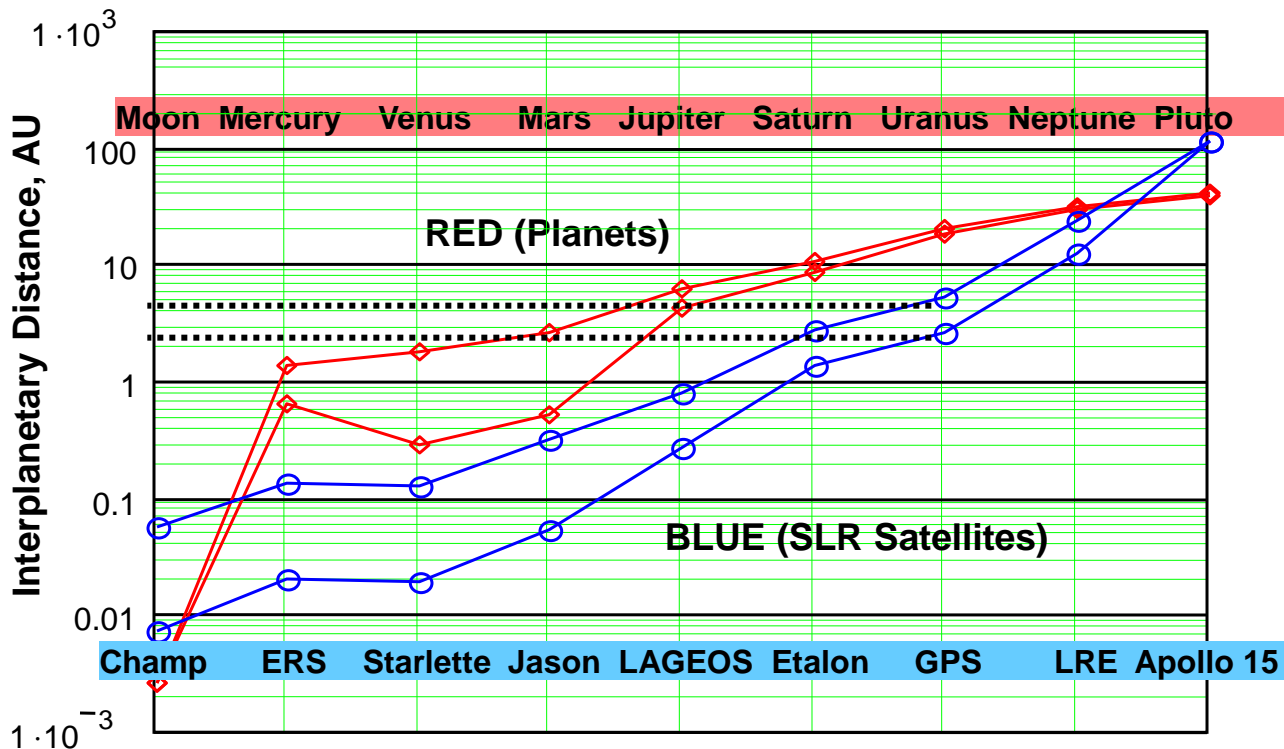

Red curves bound the Earth-planetary distance  
Blue curves bound the equivalent transponder range  
at satellite elevations of 90 and 20 degrees respectively.

\*J. Degnan, Int. J. Modern Physics D, 16, pp. 1-14 (2007).



# Summary of Equivalent Links



- Moon ( $\sim 0.0026$  AU) and Trans-lunar
  - Champ, ERS, Starlette, Jason
- Mercury, Venus, Mars (0.28 to 2.52 AU)
  - LAGEOS (near planetary PCA)
  - Etalon, GPS-35, 36 (Full planetary synodic cycle)
- Jupiter, Saturn, Uranus (4.2 to 18.2 AU)
  - GPS-35, 36 (Jupiter PCA); LRE @25,000 km
- Neptune, Pluto, Kuiper Belt (30 to 50 AU)
  - Future retro-equipped GEO satellites?
- Beyond our Solar System ( $\sim 100$  AU)
  - Apollo 15 lunar array



# Lunar Laser Communications Demonstration (LLCD)



Over the past two decades, there have been several high bandwidth lasercom experiments between Earth-orbiting spacecraft or between spacecraft and a ground station carried out or currently planned by various countries. A low bandwidth link between LOLA/LRO and NGS LR successfully transmitted an image of the Mona Lisa from lunar orbit, but the LLCD on the lunar LADEE mission recently demonstrated a bandwidth of 622 Mbps!

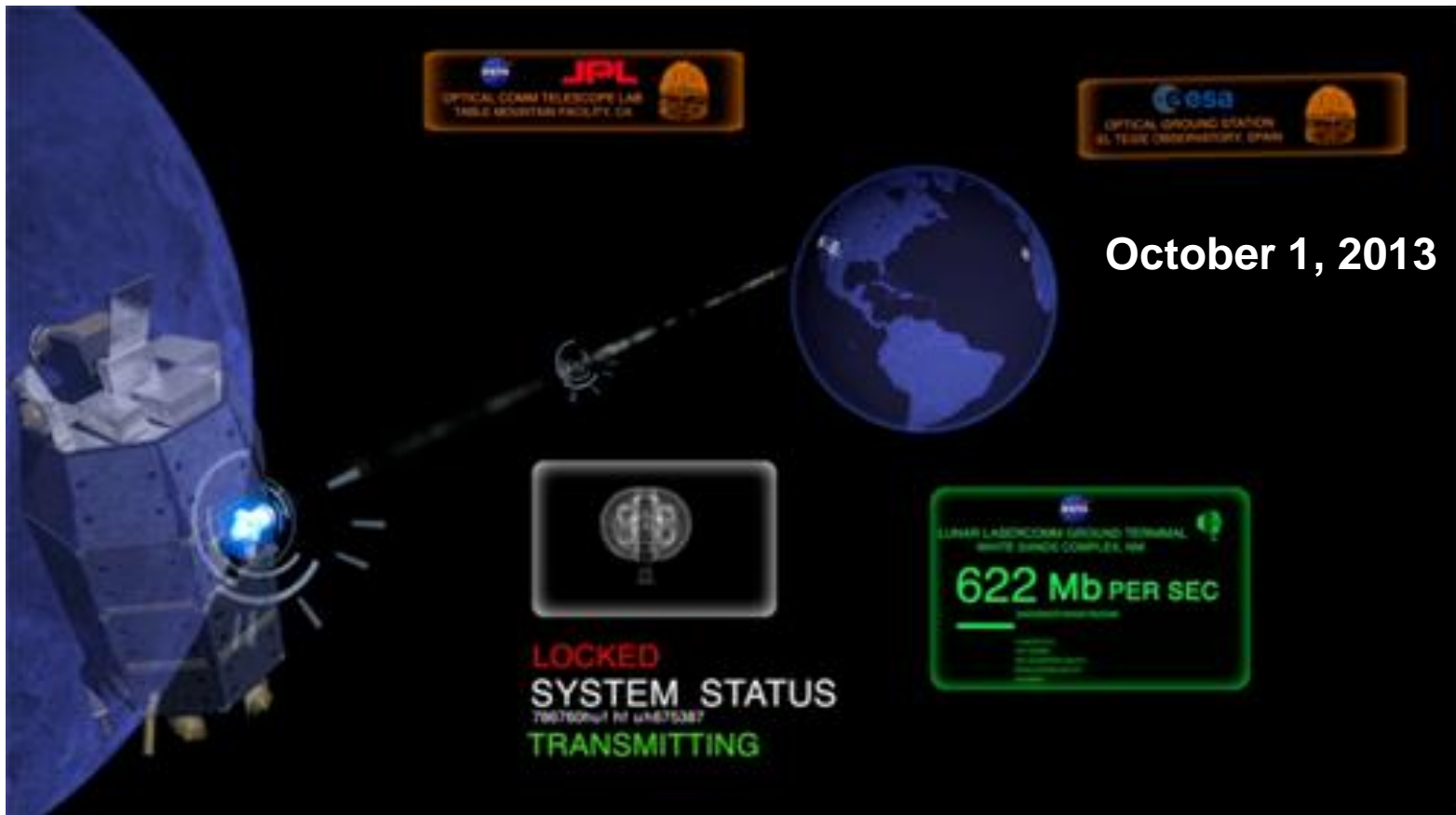



# JPL/GSFC SLR2000C Study Conclusions\*

J. Degnan et al, 14<sup>th</sup> Intl. Workshop on Laser Ranging, 2004



- Satellite laser ranging and lasercom applications are highly synergistic since most of the support capabilities required for an automated ground lasercom station are provided by the baseline SLR2000 design.
- A space-to-ground 10 Gbps downlink and 10 Mbps uplink lasercom capability can be added to SLR2000 for a differential replication cost of about \$600K at an eyesafe wavelength of 1550 nm using COTS telecom parts.
- Excellent atmospheric transmission and low solar scatter at 1550 nm.
- Range returns from a passive reflector provide independent verification of satellite acquisition and lock.
- An onboard CCD array can view the upcoming ranging beacon through a 532 nm filter for initial acquisition, identification of the active ground station, and initial pointing of the onboard lasercom terminal; 532 quadrant detectors at both terminals further refine the pointing .
- Transponders can be substituted for passive reflectors over lunar and/or deep space links; both lasercom data rates and range returns will fall off as  $R^{-2}$  for a given transmitter power/receive aperture product. A 25 site SLR2000C network can downlink ~100Mbps from lunar orbit with > 99% availability. All of the chosen sites had access to MCI Internet hubs.
- Multi-user support increases the likelihood for funding of a substantial global network which would benefit both geodesy and global communications.



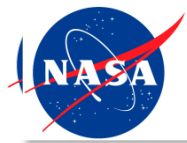

# Geosynchronous SLR2000C Coverage ( $>20^\circ$ elevation, 25 ground stations)

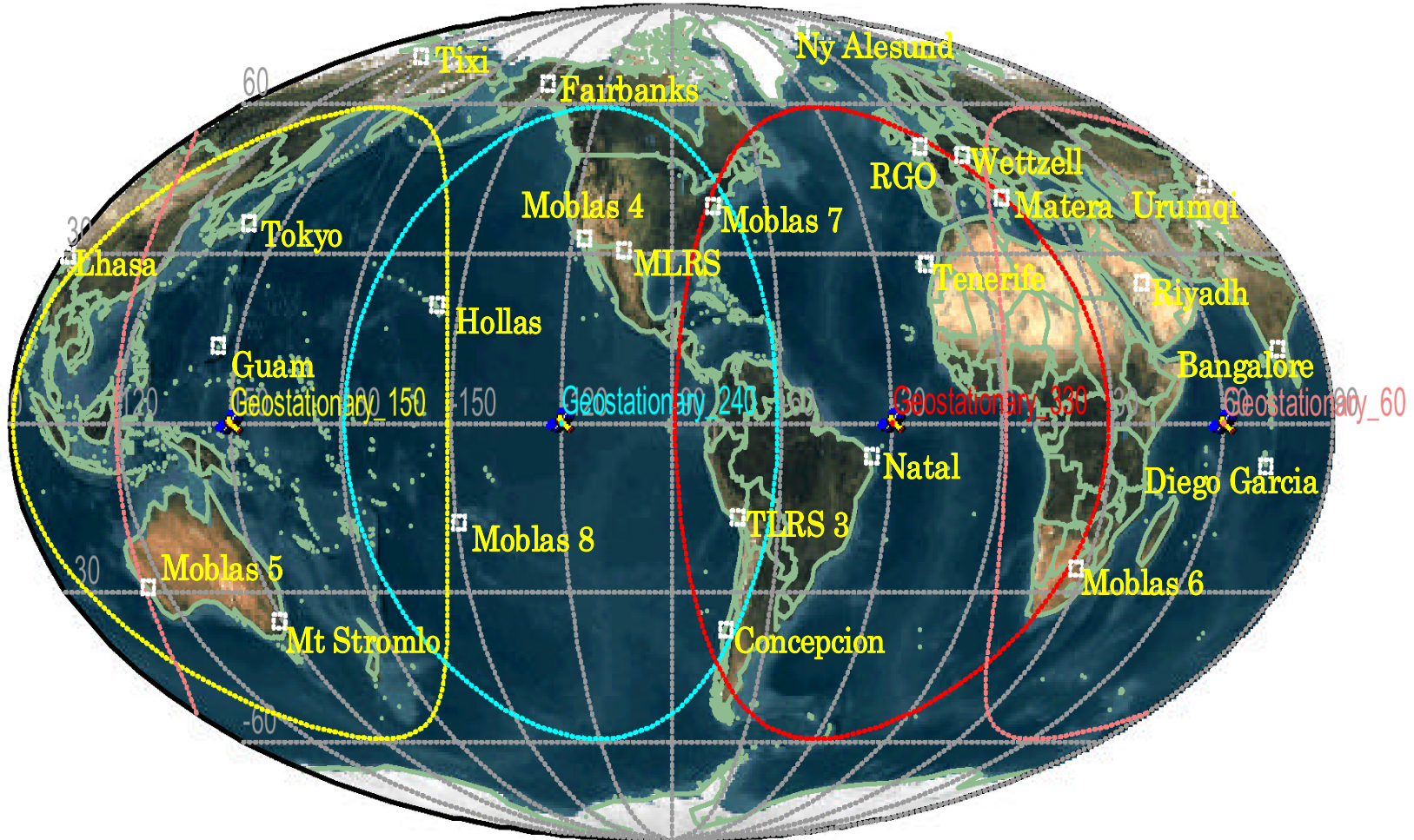



# Spaceborne Laser Altimetry

(adapted from J. B. Abshire, GSFC)



Compared to microwave altimeters, lasers have much better spatial resolution and range precision. All spaceborne laser altimeters to date have utilized 2<sup>nd</sup> generation SLR technology.

**Apollo**, - Moon  
NASA (1971-1972)  
Ruby laser,  
5,000 shots



**Clementine** - Moon  
LLNL/NRL (1994)  
Nd:YAG laser,  
~72,000 shots

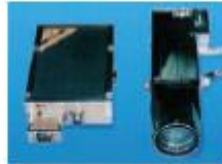

**SELENE/LALT** - Moon  
Japan (2007-present)  
Nd:YAG laser,



**Chang'E** - Moon  
China (2007-present)  
Nd:YAG laser



**MGSMOLA** - Mars  
NASA GSFC (1992,  
1996 -2000)  
Nd:YAG laser,  
670 Million shots

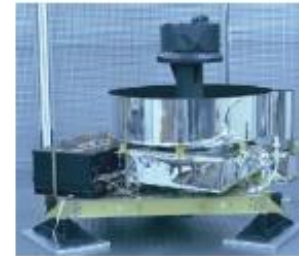

**NEAR/NLR** - Eros  
JHU/APL (96-2001)  
Nd:YAG laser,  
11 Million shots



**MESSENGER/MLA** - Mercury  
NASA GSFC (2004-2012)  
Nd:YAG laser,  
12M shots (planned)



**CALIPSO/CALIOP** - Earth  
NASA LaRC/ Ball Aerospace  
(2006-present)  
2 Nd:YAG lasers,  
> 2B shots to date

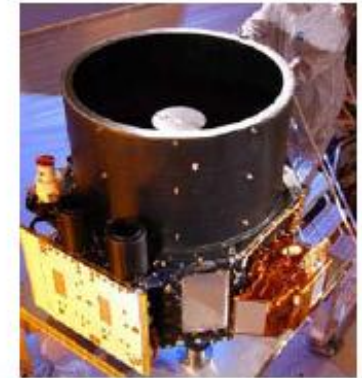

**LRO/LOLA** - Moon  
NASA GSFC (2008-now)  
Nd:YAG laser,  
>1 Billion shots

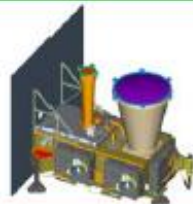

**Hayabusa** -Itokawa  
Japan (2003)

**ICESat/GLAS** - Earth  
NASA GSFC (2003-2009)  
3 Nd:YAG lasers  
1.98 Billion shots

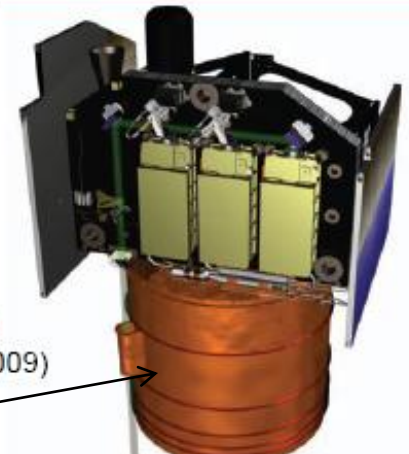





# Mars Surface Topography from MGS/MOLA (10 Hz)



MOLA Science Team

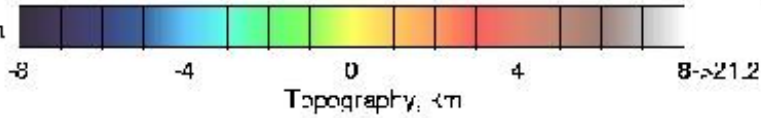

NASA-Goddard Space Flight Center

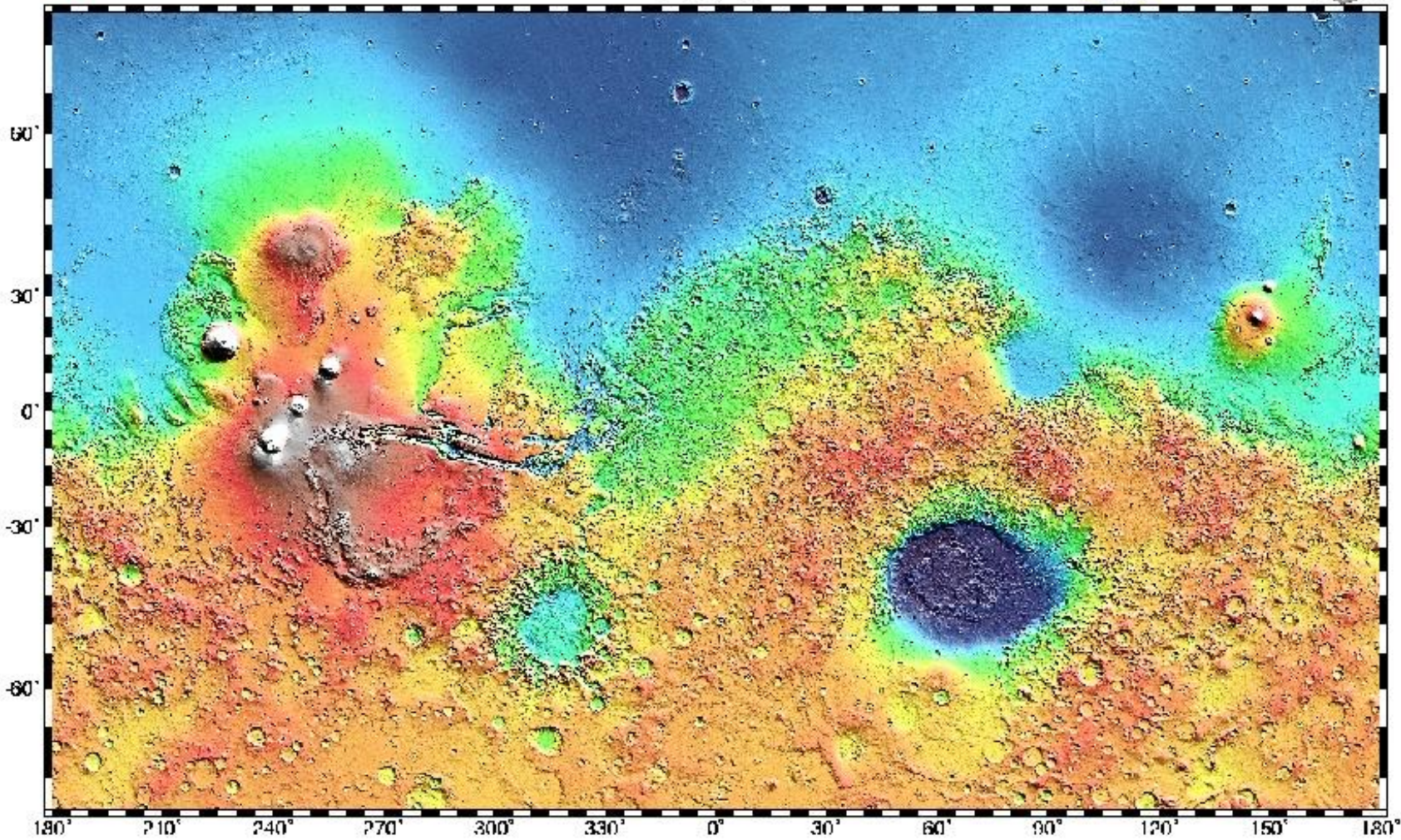

GSFC (A-3) 12365-1 (1/00) MARS MOLA



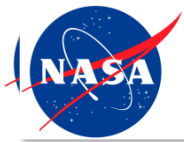

# Geoscience Laser Altimeter System (GLAS) on ICESat-1 (2003) -40 Hz

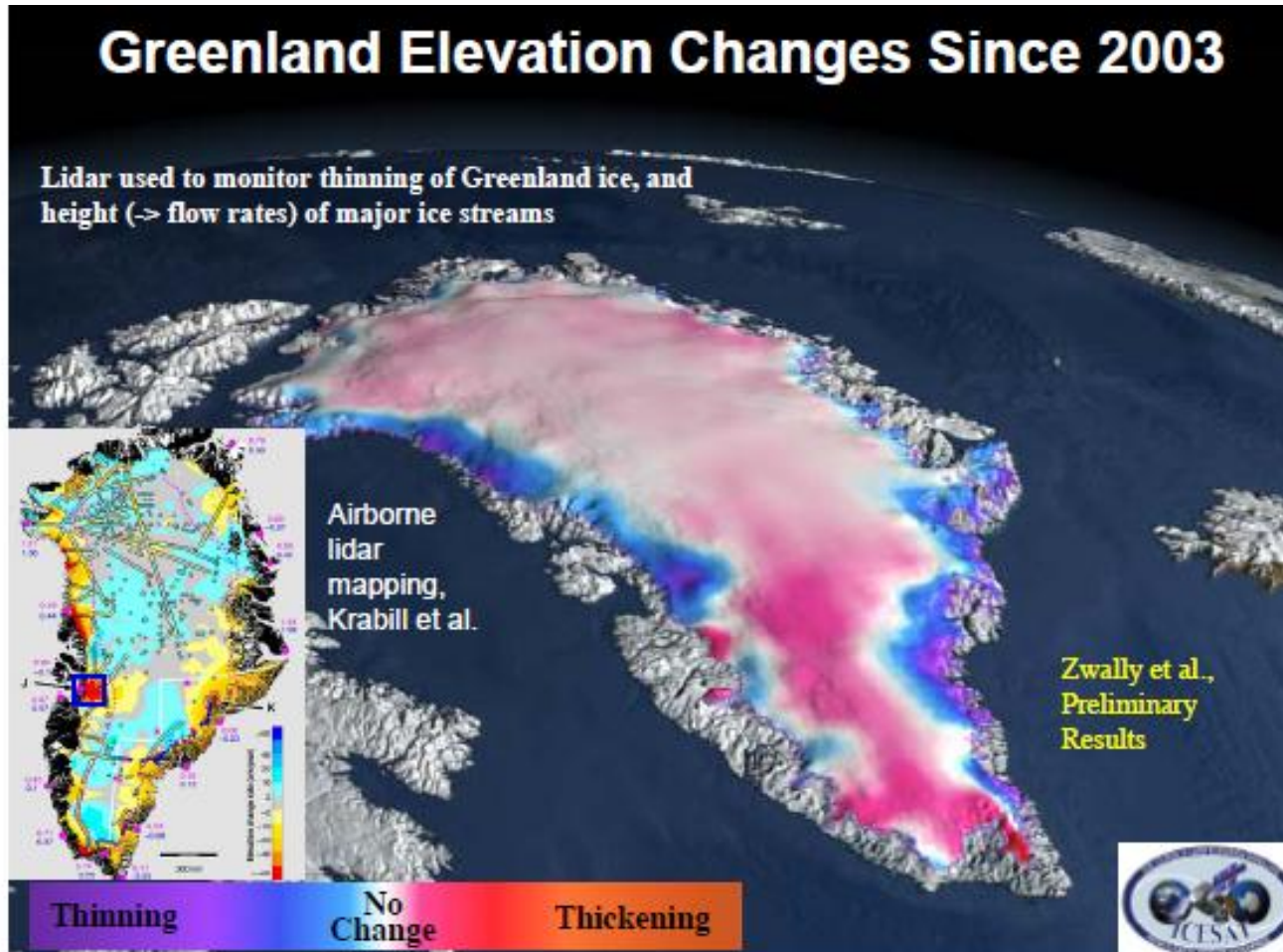

Almost 2 billion range measurements worldwide studying ice elevations, biomass, cloud heights, aerosols, etc. Following the demise of ICESat-1, NASA's Icebridge Project continues to monitor Greenland ice sheets using airborne lidars.





# Lunar Orbiter Laser Altimeter (LOLA)

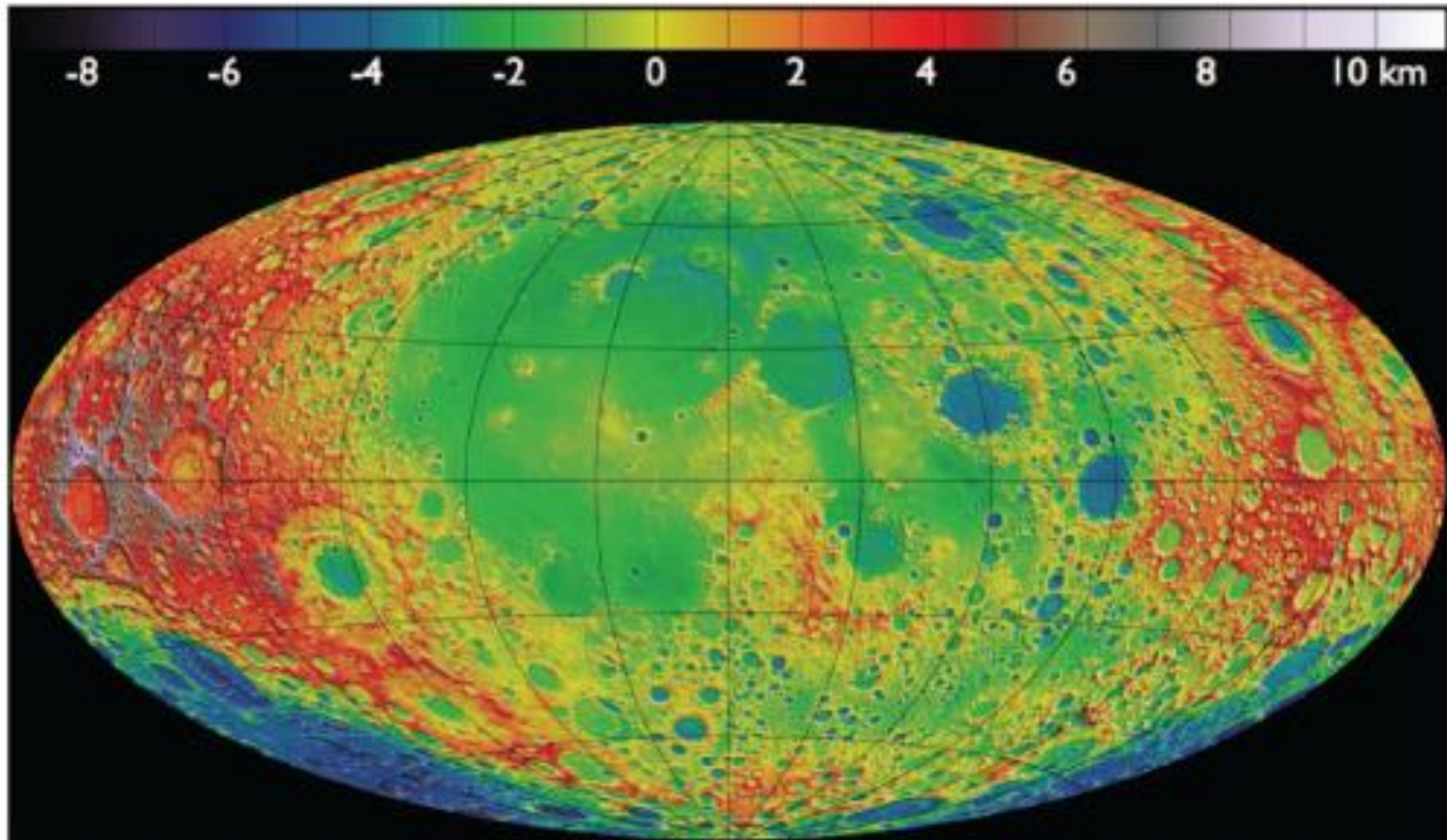

Equal-Area projection of lunar topography developed from 1 billion LOLA measurements  
Resolution: N/S ~20m; E/W ~0.1 deg (4.5km at equator, 200m at >85 Lat)

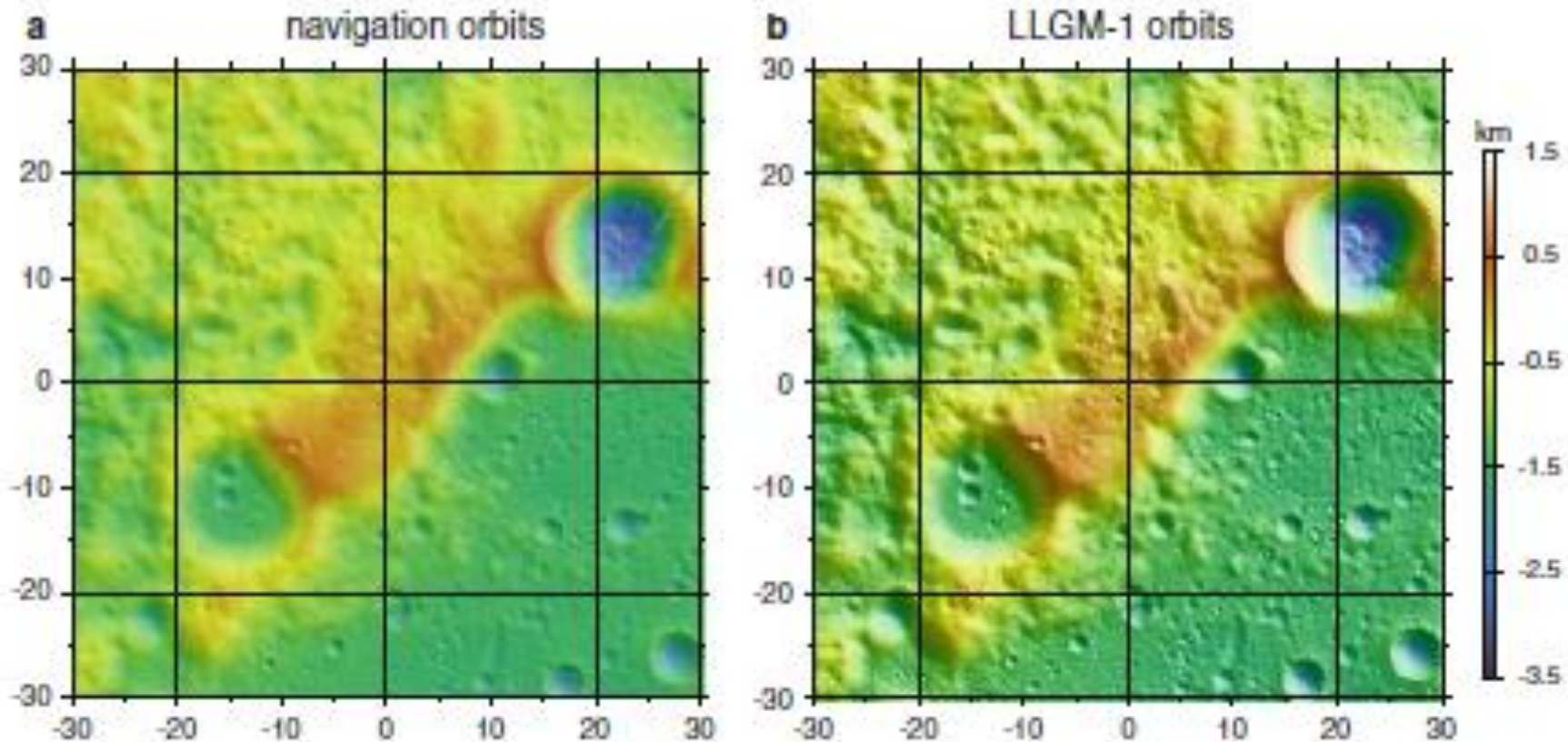

Fig. 6 Topographic maps in polar stereographic projection of the lunar north pole region (axis are in kilometers), created from LOLA data geolocated with the navigation orbits (a) and with the LLGM-1 orbits (b). The map resolution is 20 m (true scale at the pole)

LLGM-1 orbits utilize LOLA altimetric crossovers to improve the spatial resolution.





# Bouguer Gravity from NASA's Gravity Recovery and Interior Laboratory (GRAIL) and Lunar Reconnaissance Orbiter (LRO) Missions

Courtesy: NASA/GSFC Science Visualization Studio

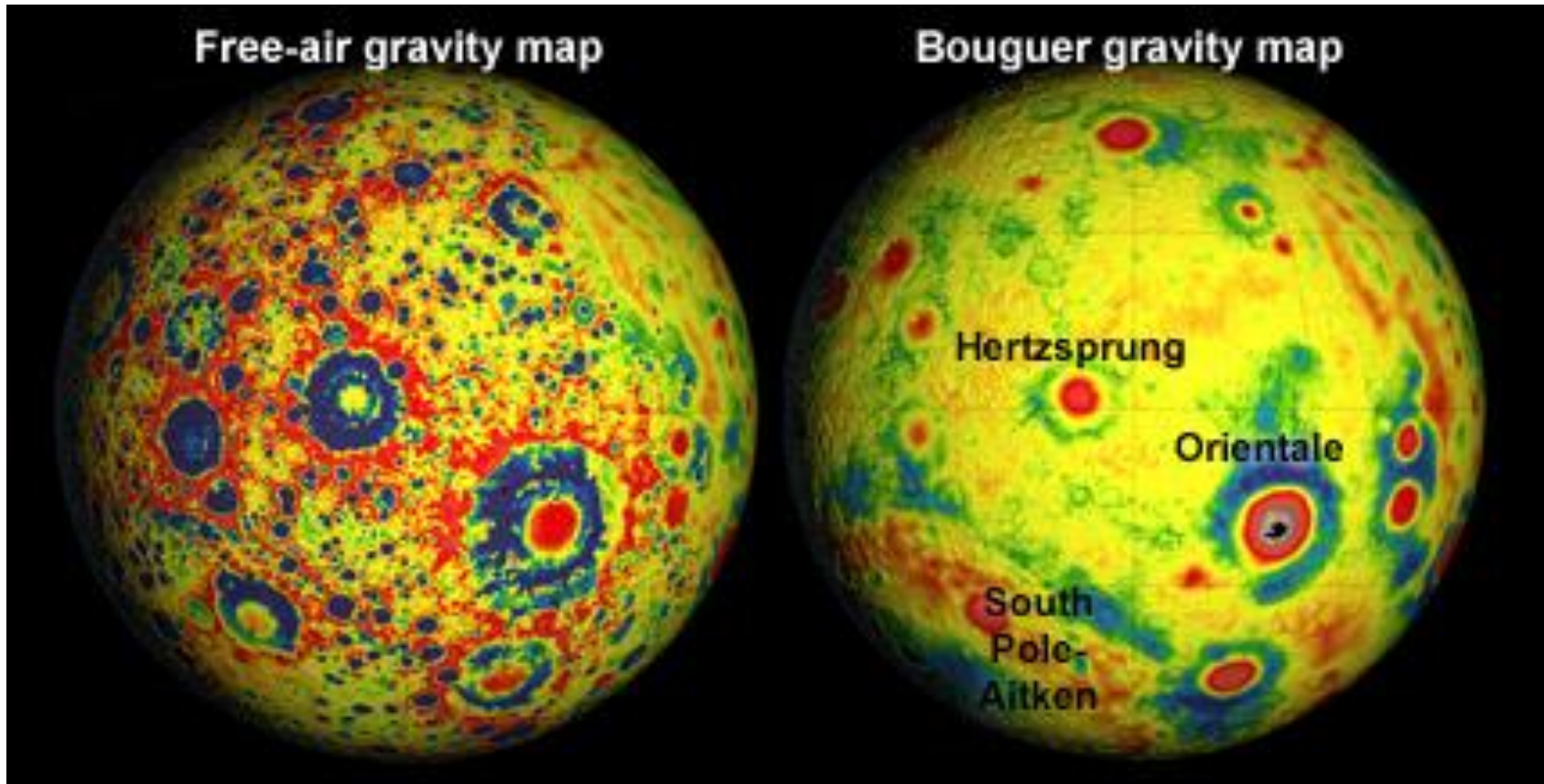

GRAIL's "free-air" gravity map (*left*) shows deviations caused by both the Moon's bumpy surface and its lumpy interior. The Bouguer gravity map (*right*) removes effects of topography to reveal density variations underneath the surface (such as *mascons* underlying large impact basins). These views show the lunar far side, centered on 120 degrees west. These detailed GRAIL gravity maps provide more accurate LRO orbits and improved science products.



# Future Spaceborne Altimetry Missions



## Earth\*

Advanced Topographic Laser Altimeter System (ATLAS) on ICESat-2 (NASA- eat. Launch 2017)  
– 6 beams @ 10 kHz = 60,000 surface measurements per second

## Mercury\*

Bepi-Colombo Altimeter on Mercury Planetary Orbiter (ESA/JAXA - 2023)

## Asteroid

OSIRIS-Rex Laser Altimeter (OLA) on Origins Spectral Interpretation Resource Identification Security Regolith Explorer (Univ. of Arizona, CSA/NASA )

\*These missions will use some 5<sup>th</sup> generation photon-counting technology, but future spaceborne systems can have orders of magnitude higher surface measurement rates (~1 Million pixels per sec) and correspondingly higher horizontal resolution.





# Sigma Single Photon Lidars



- Single Photon Lidar (SPL) is an operational technology proven by multiple instruments flying today at altitudes between 2 kft and 65 kft and at aircraft speeds up to 220 knots (407 km/hr).
- Our 100 beam scanning lidars provide contiguous, high resolution, topographic and bathymetric coverage on a single overflight with decimeter level (horizontal) and few cm RMS (vertical) resolution. Resolution of HAL instrument at 28 kft is comparable to that of HRQLS at 7.5 kft.
- Underlying terrain is interrogated at rates between 2.2 and 3.2 million 3D multi-stop pixels per second.
- Our high QE (40%), low deadtime (1.6 nsec) photodetectors and range receivers permit operation under full solar illumination and allow multiple tree canopy returns per pixel on a single pulse.
- We are currently implementing inflight algorithms to edit out solar and/or electronic noise and to correct for atmospheric effects in preparation for near realtime 3D imaging.
- Our smallest lidar, Mini-ATM, was designed for cryospheric measurements, weighs 28 pounds (12.7 kg) , occupies 1 ft<sup>3</sup> (0.028 m<sup>3</sup>), has a  $\pm$  45 degree conical scan, fits in a Viking 300 mini-UAV, consumes 166 W, and is designed to cover more area with substantially higher spatial resolution than the much larger and heavier predecessor NASA ATM system.
- SPL technology scales readily to orbital altitudes. Using a laser comparable to that developed for the ATLAS pushbroom lidar on ICESat-2 (5W @ 10 kHz) and a MOLA-sized telescope (~50 cm), one could globally and contiguously map three Jovian moons (Ganymede, Callisto, and Europa) from a 100 km orbit with better than 5 m horizontal resolution and decimeter range resolution in less than 2 months each.



# MODERATE ALTITUDE HRQLS

(High Resolution Quantum Lidar System)



Size: 48 cm x 63 cm x 83 cm (0.25m<sup>3</sup>)  
Measurement Rate: up to 2.5 million 3D pixels/sec  
A/C Design Velocity:  $\leq 200$  knots  
AGL Range: 6.5 to 18 kft

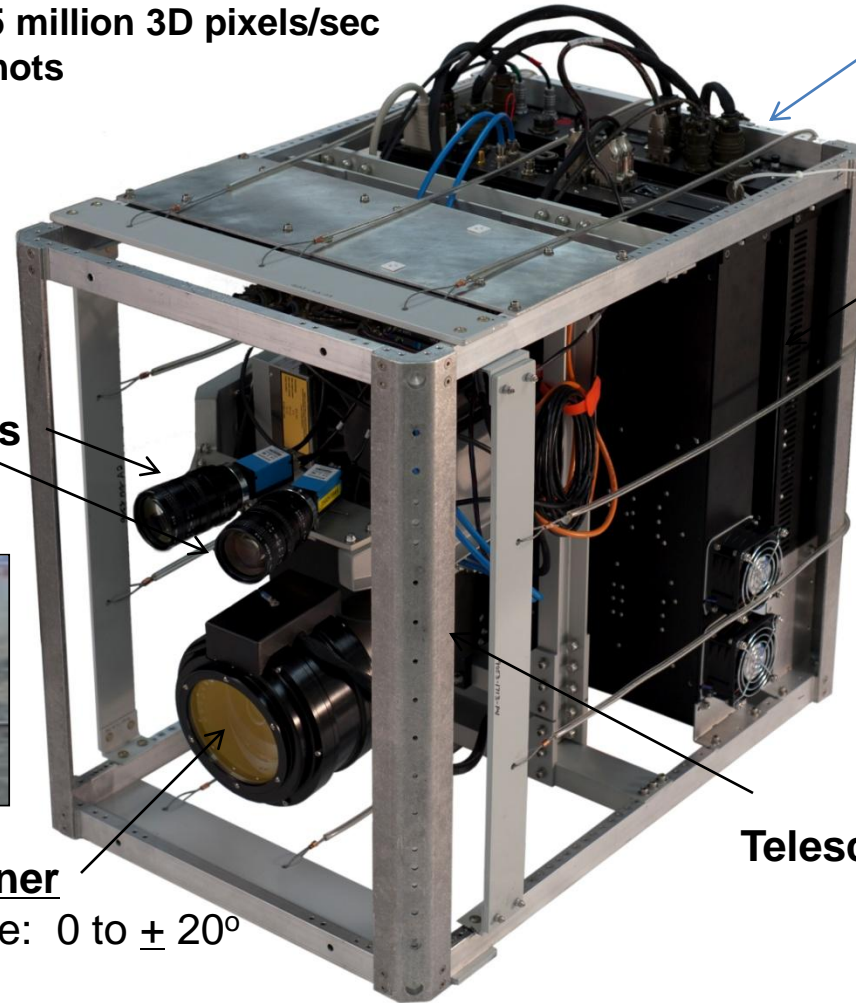

Multichannel Ranging Receiver

Laser

Two wide angle cameras



King Air B200



Telescope

Dual Wedge Scanner

Variable Cone Angle: 0 to  $\pm 20^\circ$



# HRQLS 3D mapping of Garrett County, MD in 12 hours for NASA Carbon Monitoring Study

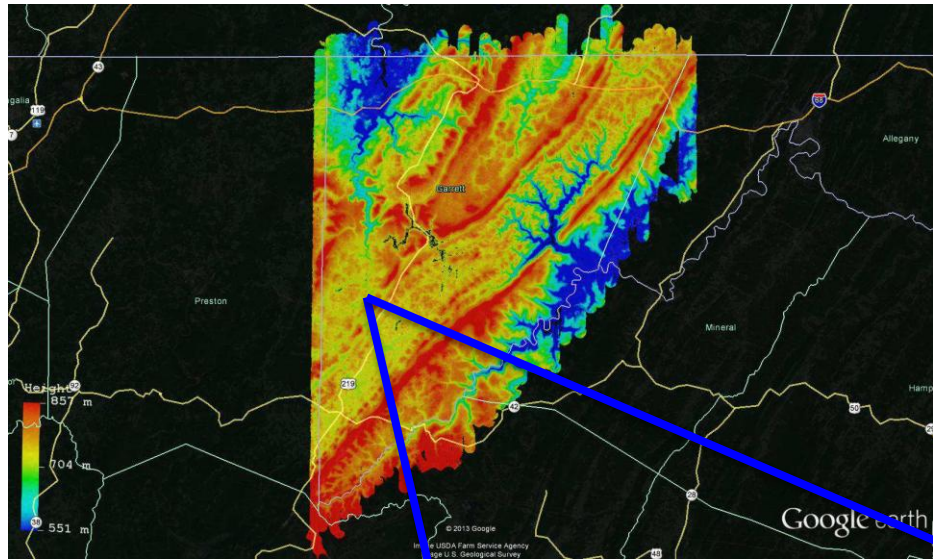

Google earth

miles 30 60  
km

Rapid 3D mapping of an entire county  
(1,700 km<sup>2</sup>) in high spatial resolution

Velocity = 150 knot (278 km/hr)

Scan Angle =  $\pm 17$  deg

AGL = 7500 ft (2.3 km)

Swath = 1.36 km

Coverage: 378 km<sup>2</sup>/hr

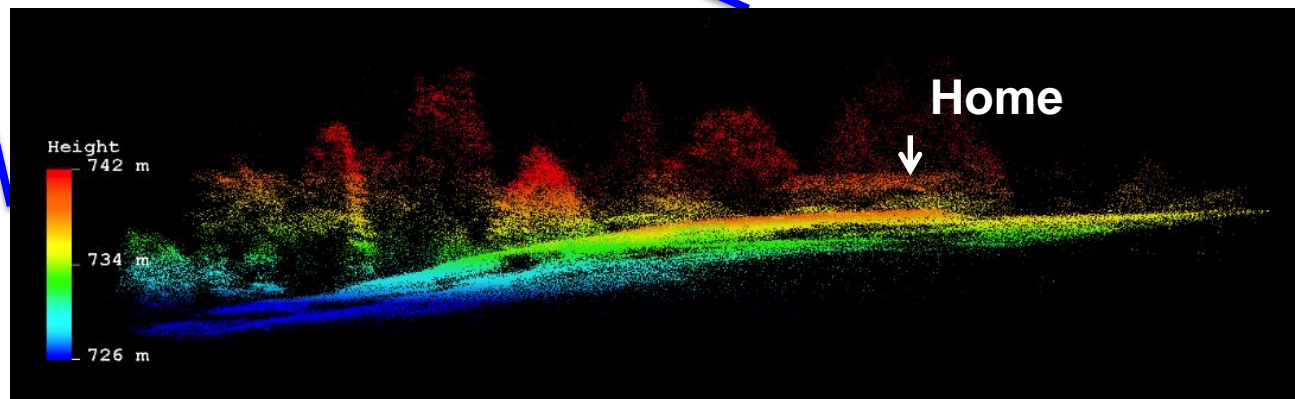





# Garrett County Coal Storage and Processing Facility

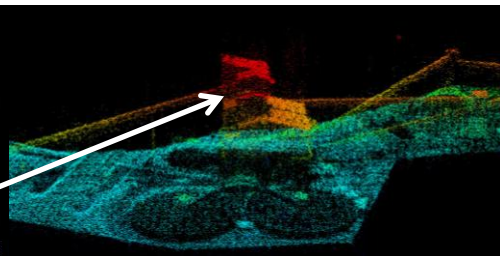
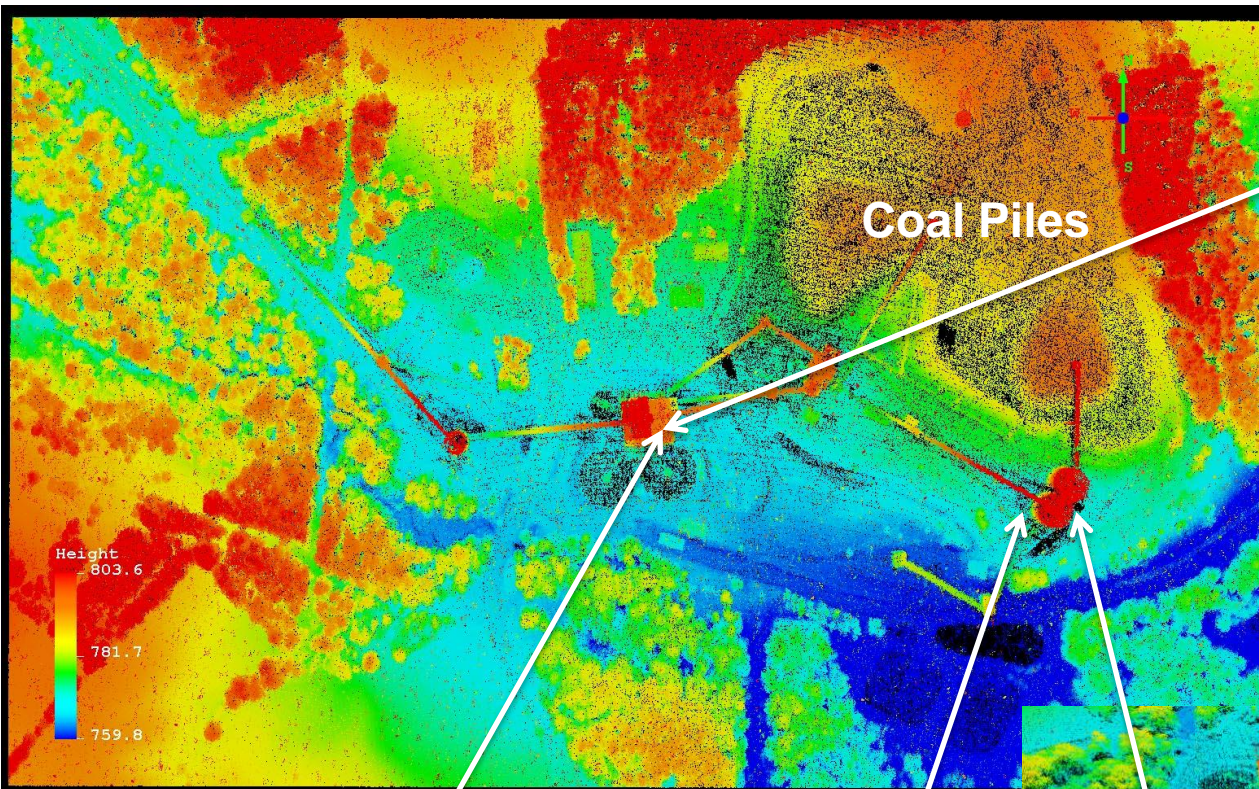

**Velocity = 150 knot (278 km/hr)**  
**Scan Angle =  $\pm 17$  deg**  
**AGL = 7500 ft (2.3 km)**  
**Swath = 1.36 km**  
**Coverage: 378 km<sup>2</sup>/hr**  
**Elev. Scale: 767 to 795 m**  
**Blue to Red**

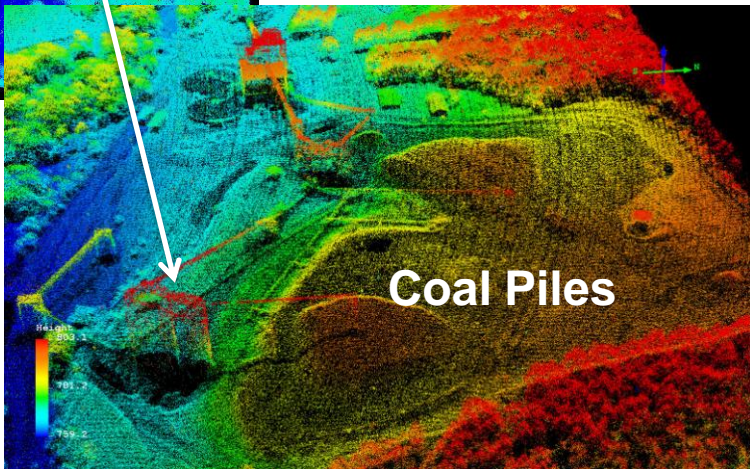
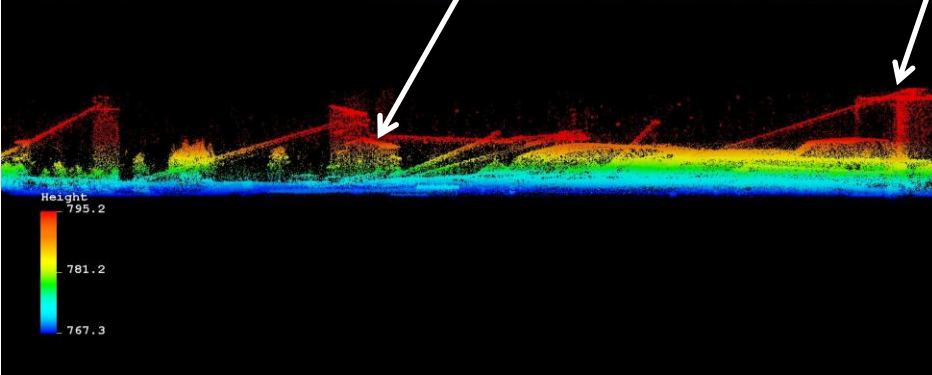





# Multistage Noise Filter

## HRQLS data over town of Oakland, MD



Originally, our SPL data was filtered following download of both surface data and noise into a point cloud generator. We have recently developed and tested a multistage filter which can be implemented on a single pulse or small number of consecutive pulses ( $\leq 10$ ). The goal is to reduce both onboard data storage requirements and data download/preprocessing times and ultimately permit the real time display or transmission of relatively “clean” 3D images.

- 1<sup>st</sup> stage rapidly isolates the surface returns from the solar background and typically discards ~ 94% of the raw noise
- 2<sup>nd</sup> stage acts on single pulse returns and, using Poisson statistics and 1<sup>st</sup> stage information, discards > 90% of the 1<sup>st</sup> stage residual noise.
- 3<sup>rd</sup> stage (under development) is designed to remove isolated noise counts in the vicinity of actual target surfaces.

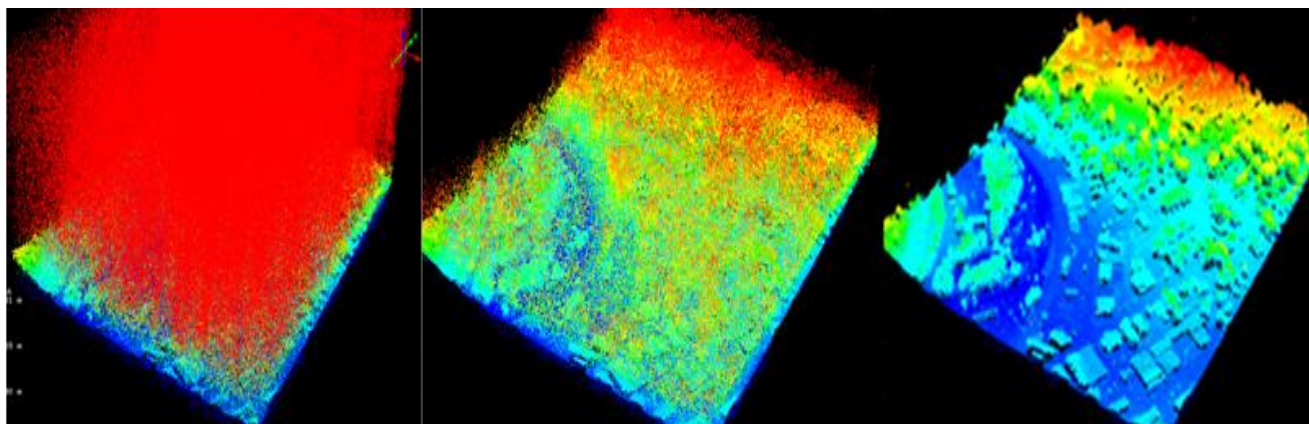

Raw/Unfiltered

1<sup>st</sup> Stage Filter

2nd Stage Filter





# HRQLS: Tree Canopies



Heavily Forested, Mountainous Area in Garrett County, Maryland  
Elevation Scale: Blue (725 m) to Red (795m) ; Delta = 70 m

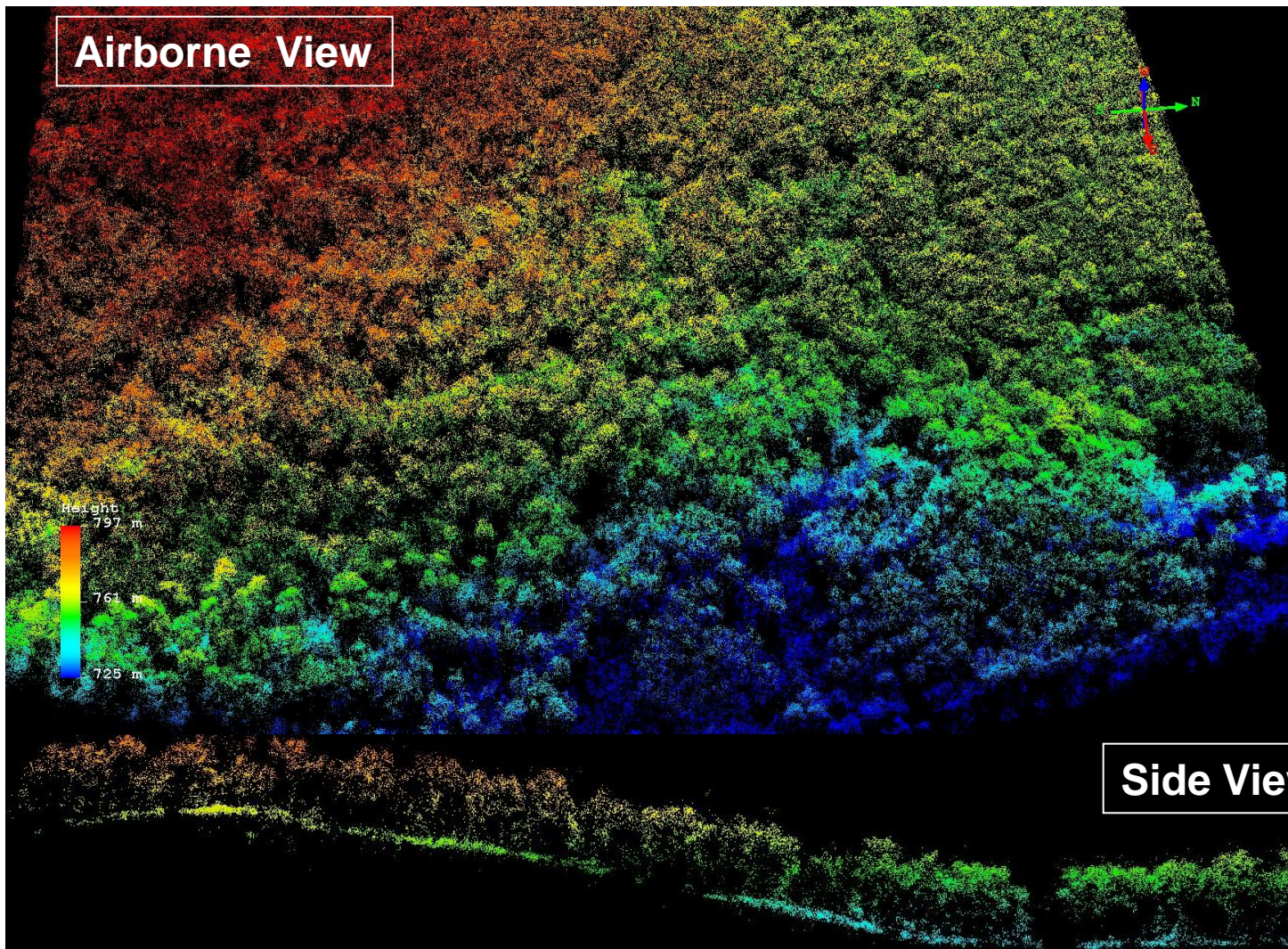



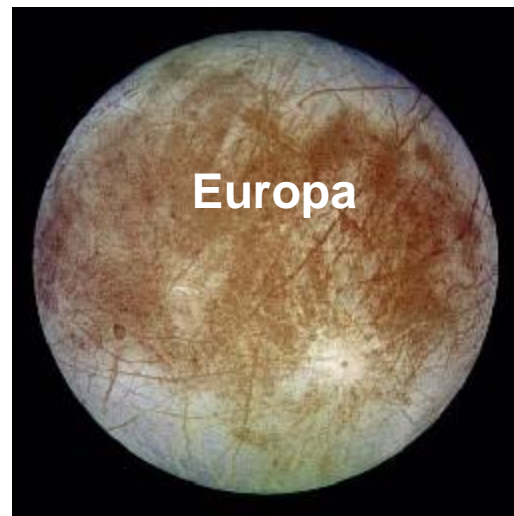

## JIMO 3D Imaging Goals

- Globally map three Jovian moons
- Horizontal Resolution: <10 m
- Vertical Resolution: < 1 m

## Worst Case Constraints

- Europa (last stop) map must be completed within 30 days due to strong radiation field
  - 348 orbits at 100 km altitude
  - 14.5 km mean spacing between JIMO ground tracks
- Surface Area: 31 million km<sup>2</sup>

\*J. Degnan, Sigma Space Corp, 2006.



# Summary: Science Impact of SLR/LLR



## • Centimeter Accuracy Orbits

- Test/calibrate microwave navigation techniques (e.g., GPS, GLONASS, DORIS, PRARE)
- Supports microwave and laser altimetry missions for global land topography, sea level, polar ice, and tree biomass measurements. (TOPEX/Poseidon, ERS 1&2, GFO, JASON, ICESat)
- Support gravity missions (e.g. CHAMP, GRACE, Gravity Probe B)

## • Terrestrial Reference Frame

- Geocenter motion
- Scale (GM)
- 3-D station positions and velocities

## • Earth Gravity Field

- Static medium to long wavelength components
- Time variation in long wavelength components due to mass redistributions within the solid Earth, oceans, cryosphere, and atmosphere
- Free Air/Bouguer gravity
- Atmospheric Drag & Radiation Pressure Models

## • Geodynamics

- Tectonic plate motion
- Regional crustal deformation at plate boundaries

## • Earth Orientation Parameters (EOP)

- Polar motion
- Length of Day (LOD)

## • Global Time Transfer

## • Lunar Physics (LLR)

- Centimeter accuracy lunar ephemerides
- Lunar librations (variations from uniform rotation)
- Lunar tidal displacements
- Lunar mass distribution
- Secular deceleration due to tidal dissipation in Earth's oceans
- Measurement of  $G(M_E + M_M)$

## • General Relativity

- Test/evaluate competing theories
- Support atomic clock experiments in aircraft and spacecraft
- LLR validates Strong Equivalence Principle (SEP)
- Constrain  $\beta$  parameter in the Robertson-Walker Metric
- Constrains time rate of change in  $G$  ( $G\text{-dot}$ )
- Measure Lense-Thirring Frame Dragging Effect (LAGEOS 1 and 2)

## • Solar System Reference Frame (LLR)

- Dynamic equinox
- Obliquity of the Ecliptic
- Precession constant

## • Interplanetary Laser Transponders and Communications

- Two-way interplanetary ranging and time transfer for improved navigation/control of spacecraft
- Solar System Science and improved General Relativity Experiments
- Stations and SLR constellation can also support interplanetary laser communications efforts