

# Developing and Deploying NASA's Space Geodesy Satellite Laser Ranging (SGSLR) Systems

**Jan McGarry**, Stephen Merkowitz, Mark Shappirio,  
Shawn Butani, Jack Cheek, Bart Clarke, John Degnan, Bud Donovan,  
Felipe Hall, Julie Horvath, Doug Lamb, Tony Mann, Alice Nelson, Tom Oldham,  
Don Patterson, Randy Ricklefs, Mark Torrence,  
Tom Varghese, Scott Wetzel, Justine Woo, Tom Zagwodzki

NASA Goddard Space Flight Center

October 30, 2014

19<sup>th</sup> International Workshop on Laser Ranging

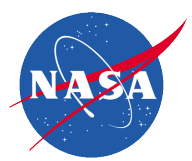

# Abstract



NASA will be building up to ten new operational Satellite Laser Ranging systems in the coming decade to be co-located with VLBI2010 systems and GNSS receivers. The first two of these new SLR systems will be deployed to McDonald Observatory in Texas and Mount Haleakala in Hawaii. These Space Geodesy Satellite Laser Ranging (SGSLR) systems will be based upon the Next Generation Satellite Laser Ranging (NGSLR) design with modifications from the lessons learned during the NGSLR development, testing, and operations. An overview of the design changes will be presented, along with the expected performance of the deployment strategy for the first two systems, and the current plans for systems three and beyond.

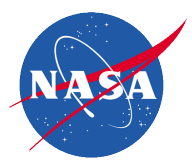

# NASA's Space Geodesy Program (SGP)



- ◆ Measurement of changes in the mean sea level will require a Terrestrial Reference Frame with an accuracy of 1 mm (decadal scale) and a stability of 0.1 mm per year (annual scale).
- ◆ To meet this need, NASA is implementing a Next Generation Space Geodesy Network, that will replace the legacy SLR and VLBI network with up to 10 globally distributed sites with co-located SLR, VLBI, and GNSS (and many with DORIS).
- ◆ SGSLR (based upon the NGSLR design) will be the station design used for this Next Generation NASA SLR Network.
- ◆ Initial deployment is planned for McDonald Observatory in Texas and Haleakala on Maui, Hawaii.



# Global Sites for SGSLR

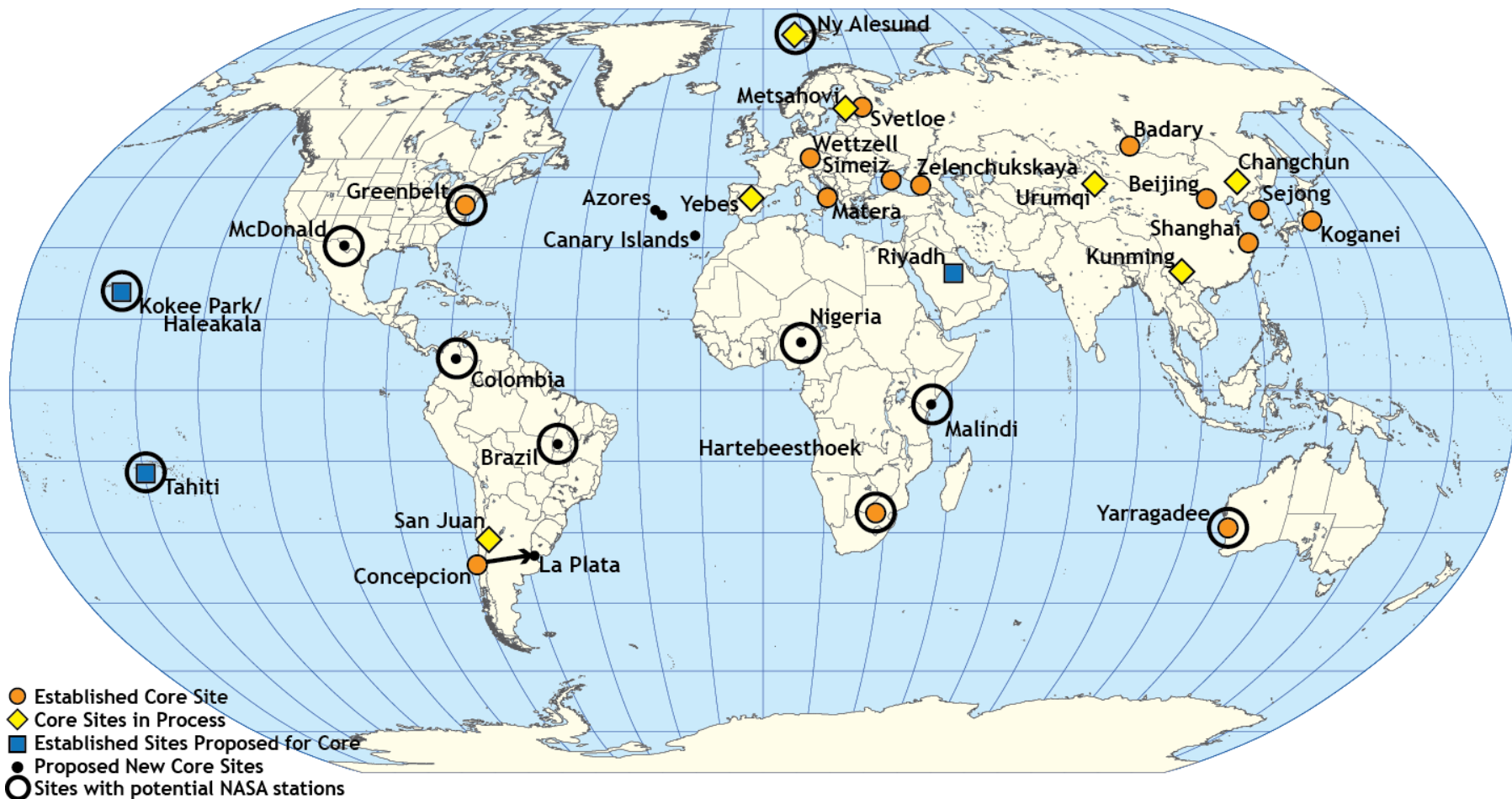

## System Requirements

- ◆ 24 hour tracking of LEO, LAGEOS & GNSS satellites
- ◆ One millimeter normal point precision on LAGEOS
- ◆ Ground cal stability at the 1mm level over hour
- ◆ Successful collocation with MOBILAS-7
- ◆ Semi-autonomous operations
- ◆ Automated aircraft avoidance laser safety system



## System Schedule

|   |           |
|---|-----------|
| Successful GNSS daylight ranging                          | Apr 2012  |
| Simultaneous ranging & system performance assessment      | June 2012 |
| New optical bench build complete                          | July 2012 |
| Performance verification of system with new optical bench | Feb 2013  |
| Semi-automated operations demonstrated                    | June 2013 |
| Collocation w/MOB-7 complete                              | July 2013 |

## Major Components

1. Shelter and dome
2. Telescope assembly
3. Tracking system
4. Optical bench
5. Laser subsystem
6. Computers & software
7. IO Chassis
8. Time & frequency
9. Receiver subsystem
10. Meteorological system
11. LHRS subsystem

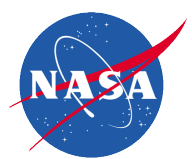

# NGSLR Performance Verified



- ◆ Met the Prototype Requirements.
- ◆ Demonstrated performance requirements during collocation with MOBILAS-7 summer 2013.
- ◆ Verified millimeter level precision for LAGEOS normal points.
- ◆ Verified range bias against theory at few millimeter level.
- ◆ Verified stable range bias over long term (1.7 mm over a one year period).
- ◆ Showed hour long stability at the millimeter level during ground calibrations.
- ◆ **Data now on CDDIS. Independent analysis by JCET. Report available.**

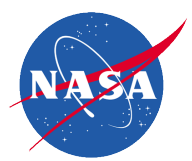

# SGSLR Changes From NGSLR

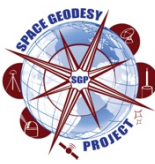

- Functionally SGSLR and NGSLR are the same but the number of subsystems and their names have changed somewhat.
- Certain changes to the Prototype design are needed because of:
  - New requirements for SGSLR
  - Lessons learned during NGSLR development & testing
  - Ease of maintenance or less costly maintenance
  - Parts obsolescence at NGSLR
- Changes are in telescope, optical bench, receiver subsystem, laser safety (aircraft avoidance for Hawaii) and computers/software.
- Working toward full automation.

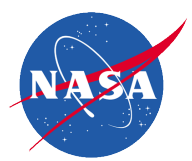

# SGSLR's Ten Subsystems



Receiver



Telescope

Tracking



SLR Laser

Shelter & Dome

Weather



Timing



Computers & Software

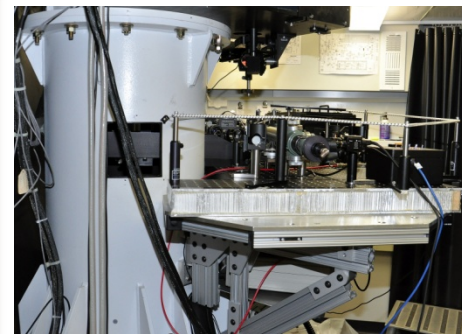

Optical Bench



Laser Safety



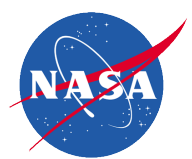

# SGSLR Design Changes



## ◆ Telescope

- purchase COTS product (50 cm)
- standard on-axis Cassegrain (NGSLR is off-axis)

## ◆ Optical Bench

- simplify design (complexity not needed since eye-safe no longer a requirement)

## ◆ Receiver Subsystem

- picosecond resolution
- support closed loop tracking

## ◆ Computers/Software

- replace obsolete computers
- replace LynxOS with real-time Linux
- complete automation software

## ◆ Laser Safety - Aircraft Avoidance for Hawaii

- look at FAA radar feed for US sites
- test TBAD

### See related posters:

Cheek (3093), "Space Geodesy Satellite Laser Ranging Computer Design"

Horvath (3136), "Automating NASA's Space Geodesy Satellite Laser Ranging (SGSLR) System"

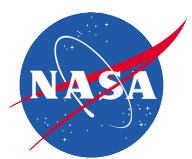

# SGSLR Performance Requirements



- Data precision for LAGEOS normal points shall have an RMS of 1.5 mm or better when averaged over a month's period.
- Over a one year period the RMS of the station's LAGEOS normal point range biases shall be 2 mm or better.
- Systems shall be capable of producing an annual normal point quantity of over 45,000 LEO ( $\leq 30$  second period), 7,000 LAGEOS (2 min period) and 10,000 GNSS (5 min period). **(New for SGSLR)**
- SGSLR shall be capable of both local and remote operation by an operator, with a clearly defined path for transitioning to a fully automated mode. **(New for SGSLR)**
- SGSLR shall have a modular design supporting maintenance and upgrades. **(New for SGSLR)**

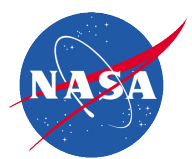

# Link Calculations in Support of Design



Effective Receive Area  $A_r = 0.174\text{m}^2$

Optical Efficiencies:  $\eta_c = 0.28$     $\eta_t = 0.746$     $\eta_r = 0.517$

Laser Parameters:  $P_t = 3\text{-W}$     $f_{qs} = 2\text{-kHz}$     $E_t = 1.5\text{-mJ}$

Pointing  $\theta_d = 3.5\text{-arcsec}$     $\Delta\theta_p = 0$     $\Delta\theta_j = 2\text{-arcsec}$

**GNSS satellites with ILRS retro-reflector response guidelines.  
Mean cloud cover, no pointing bias.**

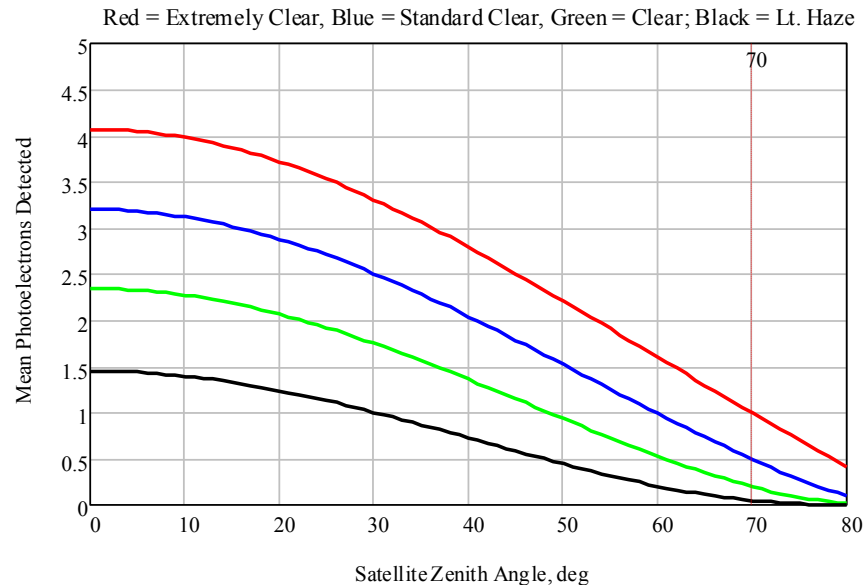
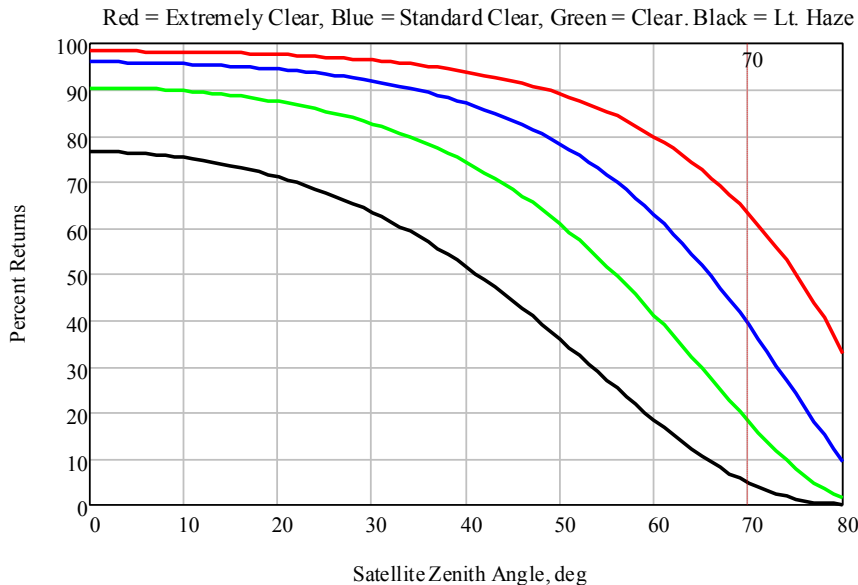

**GNSS expected return rate of > 1.5 photoelectrons / fire in a standard clear atmosphere at 45 deg elevation. For same conditions LAGEOS expected return rate > 20 pe/fires.**

Degnan



# Expected Performance (with 20 deg EL limit) Against Global Station Performance



Data volume from ILRS Global Report Card: April 2013 thru March 2014

| Site ID      | Station Number | LEO NP Totals | Lageos NP Totals | High NP Totals | Starlette ave prec mm | Lageos ave prec mm | JCET Long term stab mm |
|--------------|----------------|---------------|------------------|----------------|-----------------------|--------------------|------------------------|
| YARL         | 7090           | 176,683       | 20,634           | 21,986         | 1.7                   | 1.9                | 2.5                    |
| GODL         | 7105           | 76,554        | 7,666            | 3,052          | 1.0                   | 2.0                | 3.5                    |
| CHAL         | 7237           | 69,438        | 7,235            | 14,735         | 0.5                   | 0.8                | 4.1                    |
| ZIML         | 7810           | 94,836        | 17,517           | 17,387         | 0.1                   | 0.1                | 1                      |
| STL3         | 7825           | 78,089        | 7,218            | 3,984          | 0.8                   | 1.9                | 1.5                    |
| GRZL         | 7839           | 75,714        | 5,468            | 18,016         | 0.1                   | 0.2                | 1.8                    |
| HERL         | 7840           | 38,592        | 7,018            | 6,069          | 1.7                   | 1.9                | 1.2                    |
| MATM         | 7941           | 38,497        | 10,422           | 5,279          | 0.5                   | 0.3                | 2.5                    |
| WETL         | 8834           | 46,509        | 5,053            | 12,683         | 1.0                   | 1.6                | 3                      |
| <b>SGSLR</b> | <b>7125</b>    | <b>69,000</b> | <b>9,500</b>     | <b>15,600</b>  | <b>&lt; 1.5</b>       | <b>&lt; 1.5</b>    | <b>&lt; 2.0</b>        |

- Projected **SGSLR** annual NP data volume are conservative: assuming 50% weather outage, 15% other outage, and 50% data collection when active. No interleaving. Min 20 deg EL.
- NOTE: YARL has 14% weather outage and tracks to 10 deg EL. GODL tracks down to 10 deg EL.
- Precision and stability numbers for SGSLR are based upon NGSLR performance.

# Space Geodesy Project's Integrated Geodetic Site Operations Center (IGSOC)

Combine Operations & Monitoring Functions for SLR, VLBI and GNSS

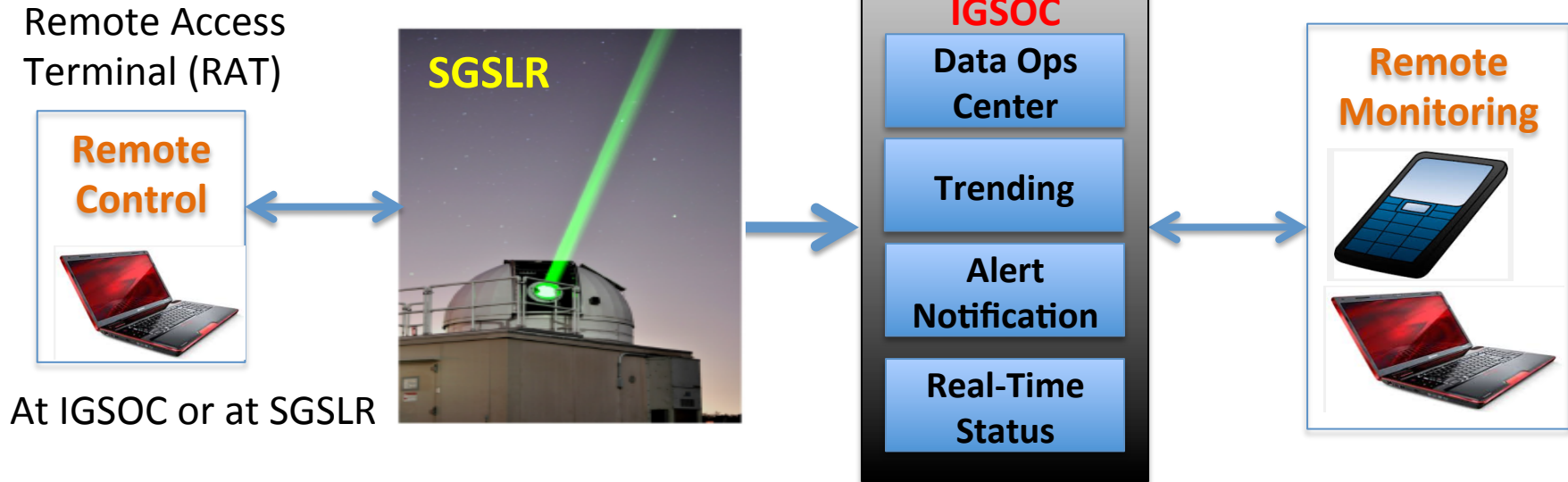

- ◆ IGSOCC receives operational NPT data and sends predictions and schedules.
- ◆ IGSOCC will receive safety, health and performance status, plus decisions made and activities performed via secure file transfer from the station.
- ◆ Limit/Threshold violations can be defined at IGSOCC, and autonomic responses can be programmed. Limit violations can result in alert notifications.
- ◆ Users can remotely access long term trending and real-time status.
- ◆ Human control of system must be through the Remote Access Terminal (RAT).

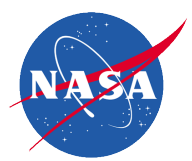

# Modes of Operations



## ◆ SGSLR Modes of Operation:

- Satellite Ranging
- System calibration
- Star calibration
- Standby / Maintenance

- ## ◆ Regardless of the mode, operations will be the same whether a human operator is physically present, remotely controlling, or not participating (automated operation). The only difference will be who makes the decisions - not what functions are performed.

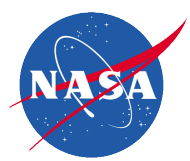

# Future Automated Operations Concept

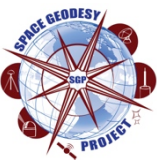

- ◆ System operates without any human intervention.
- ◆ Human can monitor remotely through IGSOCC.
- ◆ System and/or IGSOCC will send alerts (via cell phone texting) when there are problems.
- ◆ A local technician is on call at all times.
- ◆ Normal operations for SGSLR is to go back and forth between Automated and Remote operation, as humans are available, and as needed.
- ◆ The plan is to eventually operate longer and longer without any human intervention or monitoring.

# Generalized SGP Site Plan

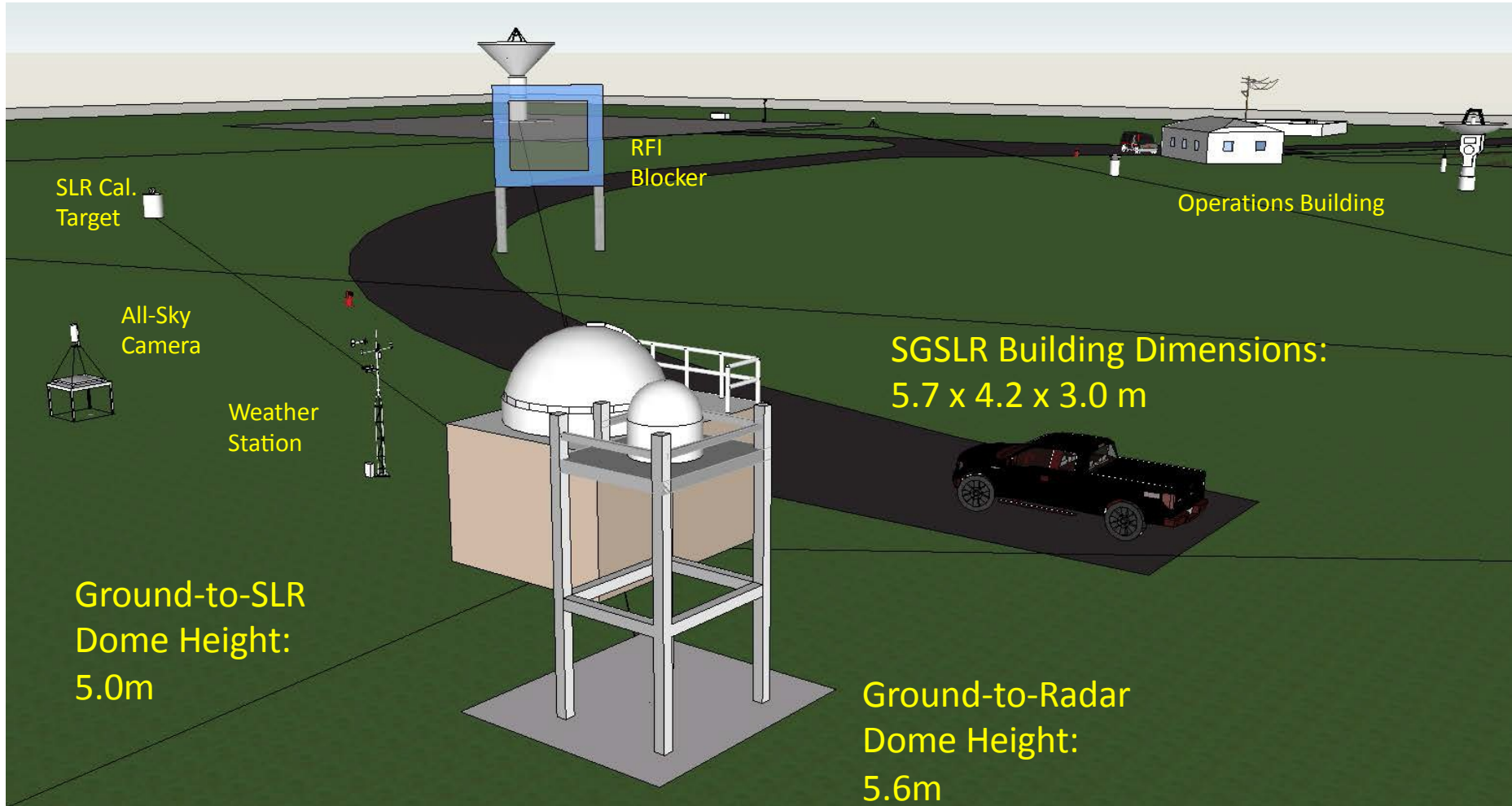

Approximate building dimensions shown



# Generalized SGSLR Site

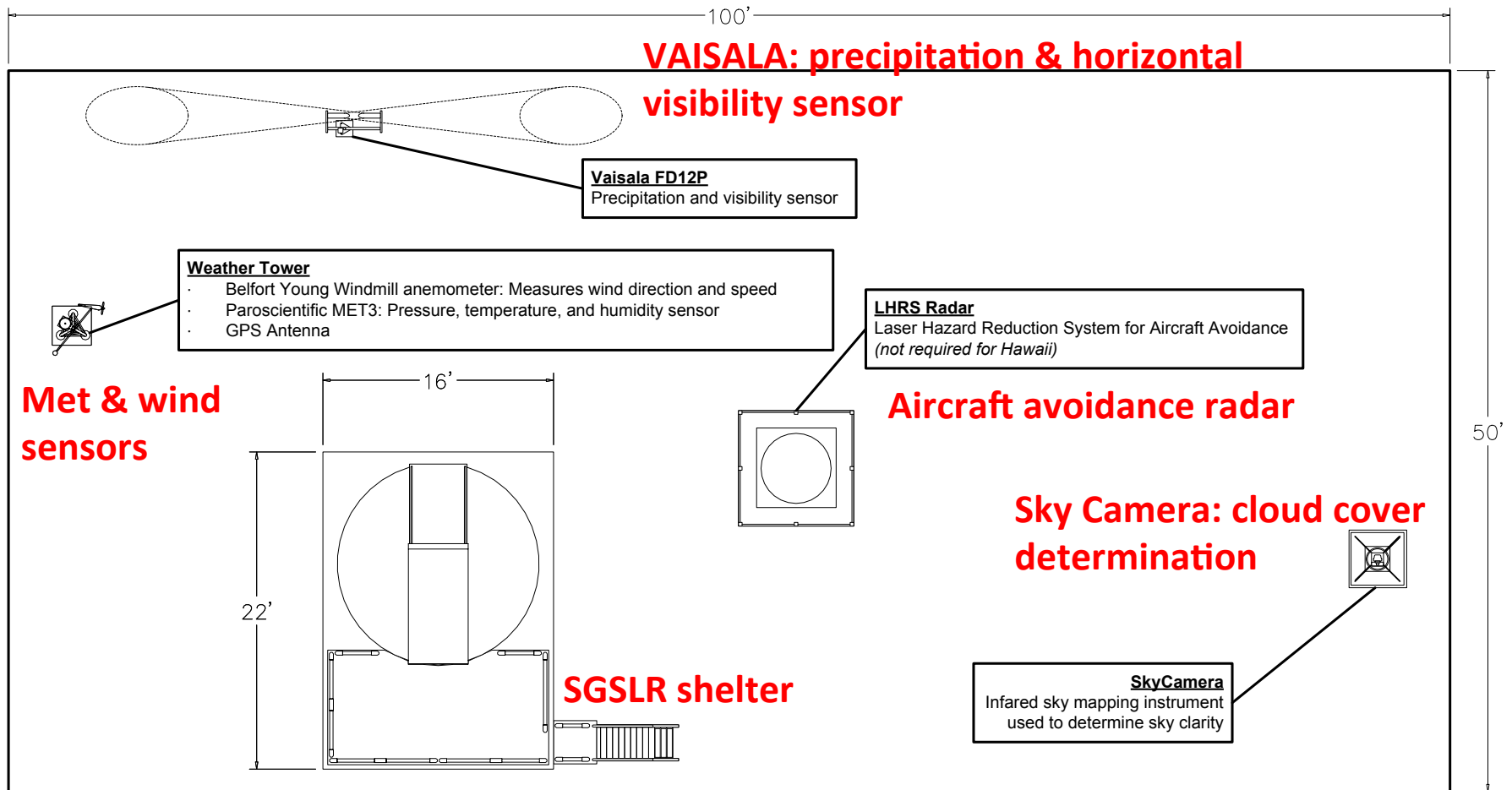

## Tentative SGSLR Site Size

8/14/2014

# GGAO Site Plan

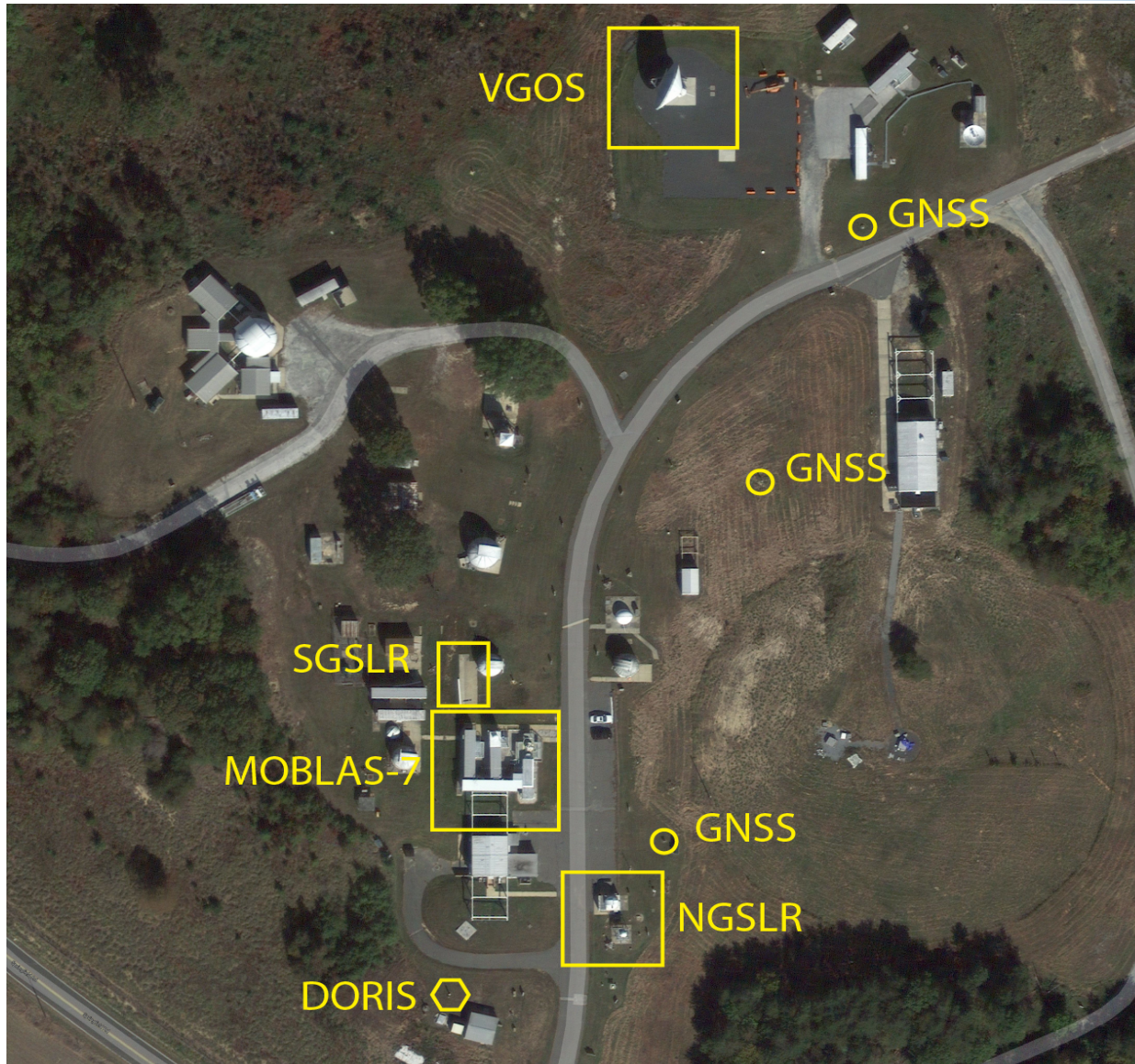

**Current plan is to build and test SGSLR systems at GGAO, and then deploy them to their final locations.**

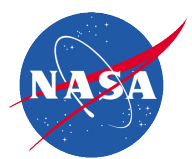

# Co-Existing with VLBI



- ◆ Interference from SLR 9.4 GHz aircraft avoidance radar causes problems for VGOS measurements, and could cause severe damage if pointed directly at VLBI antenna.
- ◆ Current methods to mitigate this at GGAO:
  - Radar is partially blocked by NGSLR building,
  - Mask is in place at both VGOS and NGSLR to prevent each from pointing within 32 degrees of the other,
  - Mask also implemented at MOBILAS-7.
- ◆ Looking to reduce the mask, as it eliminates a good number of passes for SLR, and prevents VLBI from making certain measurements:
  - Looking to implement a real-time point-to-point communication between VGOS and SGSLR to determine where each is pointing. Test at NGSLR.

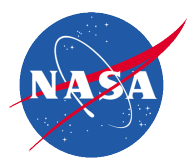

# First Deployments to Texas & Hawaii

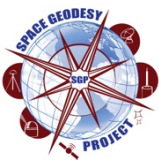

## ◆ Texas: McDonald Observatory

- SGSLR will be near MLRS location.
- VLBI at the saddle point or near Visitor's Center.
- Radar will be used for aircraft avoidance – expect no issue for VLBI due to distance.

## ◆ Hawaii: Haleakala (Maui)

- Plan to put SGSLR on FAA property - line of sight to TLRS-4.
- VLBI on Kauai (different island). No issue between SLR & VLBI.
- Cannot use radar on Haleakala. Looking at FAA radar feed and TBAD for this location.

# McDonald Observatory Area

- ◆ McDonald Observatory is located in the Davis Mountains, 450 miles west of Austin, Texas.
- ◆ The Observatory carries out imaging and spectroscopy in the optical and infrared.
- ◆ Operates the McDonald Laser Ranging System (MLRS), for space geodesy and lunar ranging.
- ◆ Large area across several locations.

**See Esper talk in this session  
on SGP site locations**

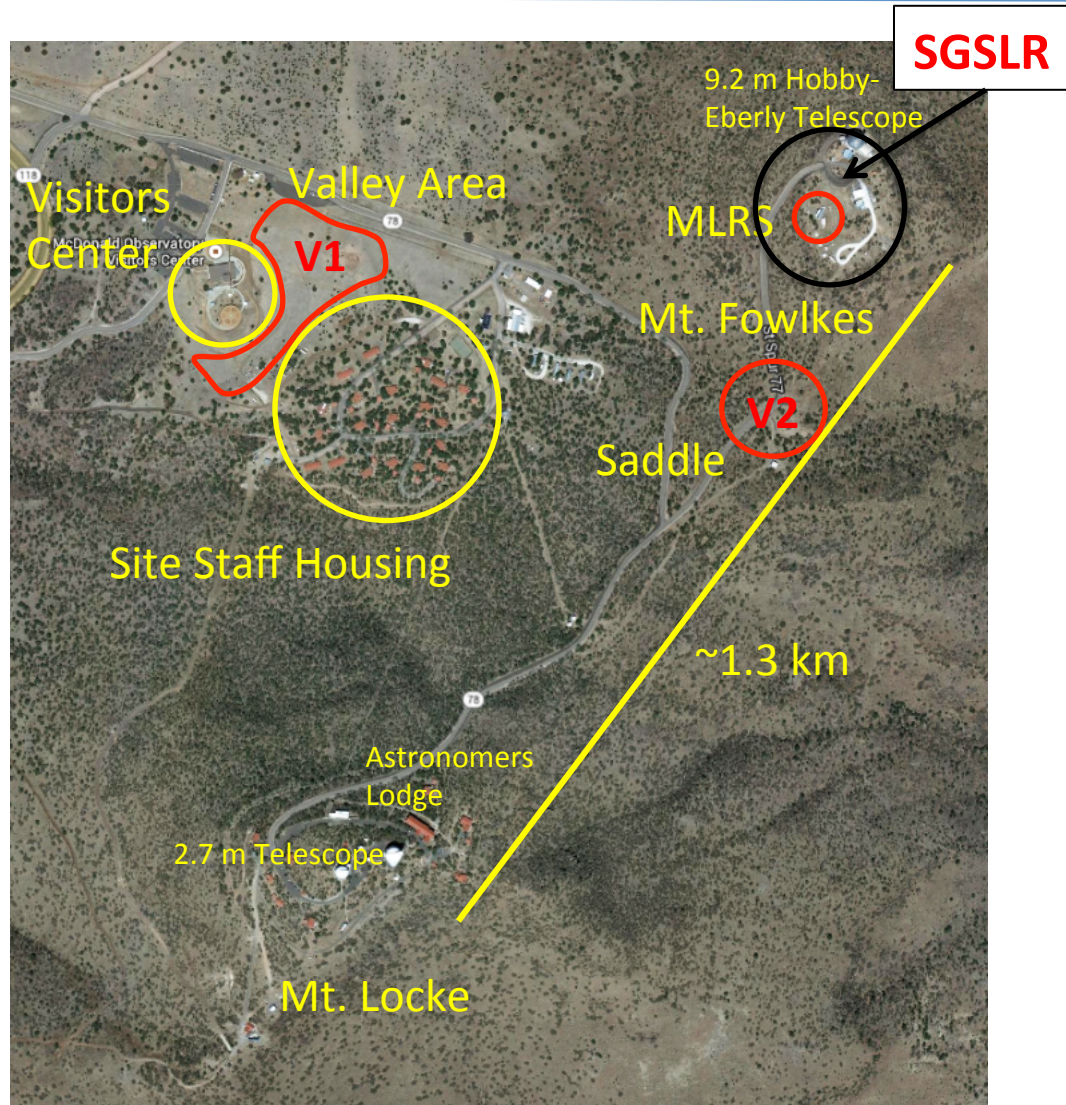

# Haleakala Site Plan

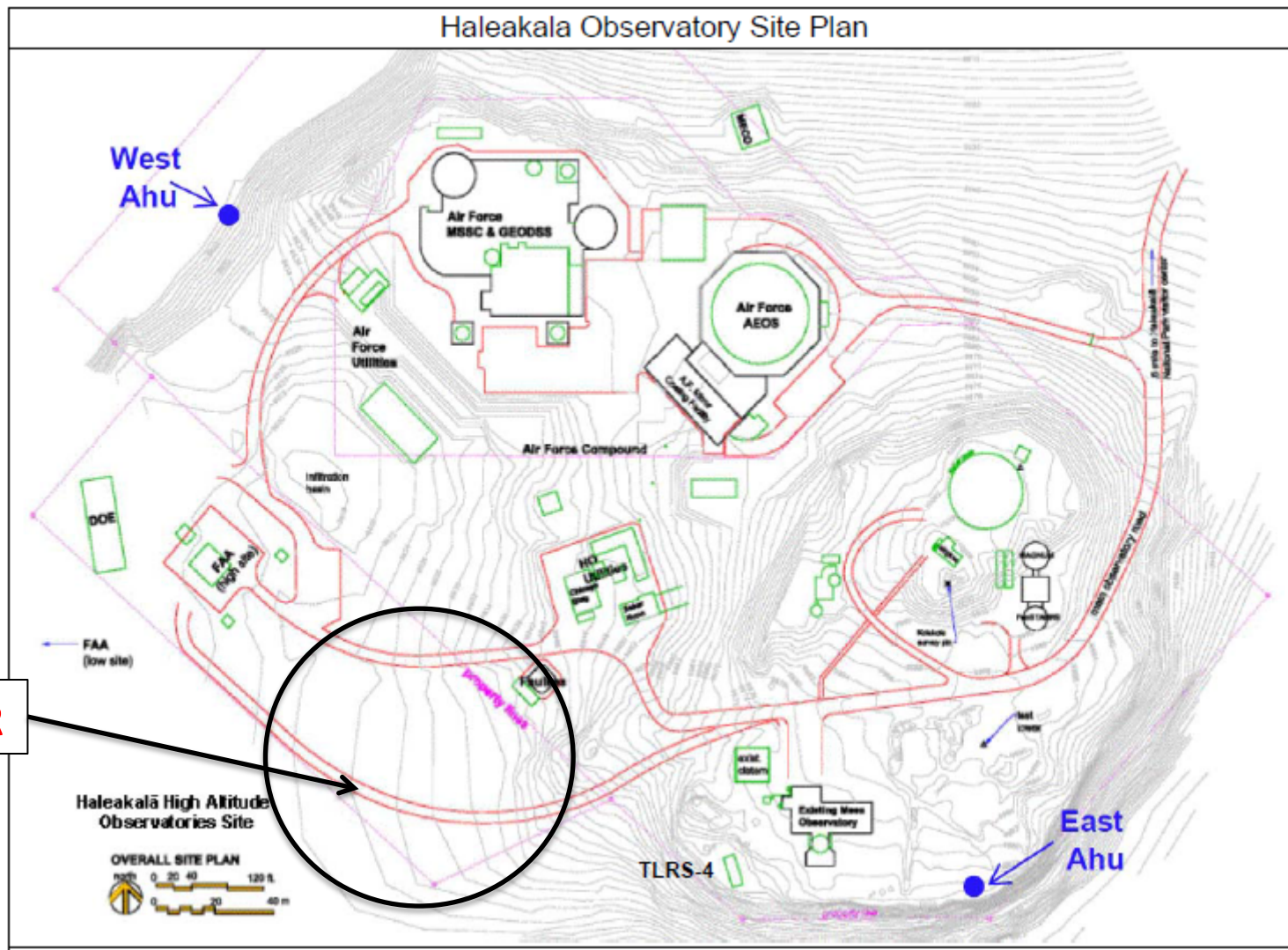

SGSLR

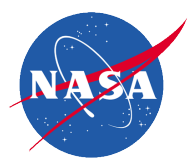

# Preliminary (& Aggressive) Deployment Schedule



## Space Geodesy Project SLR Deployment (Draft 7/25/14)

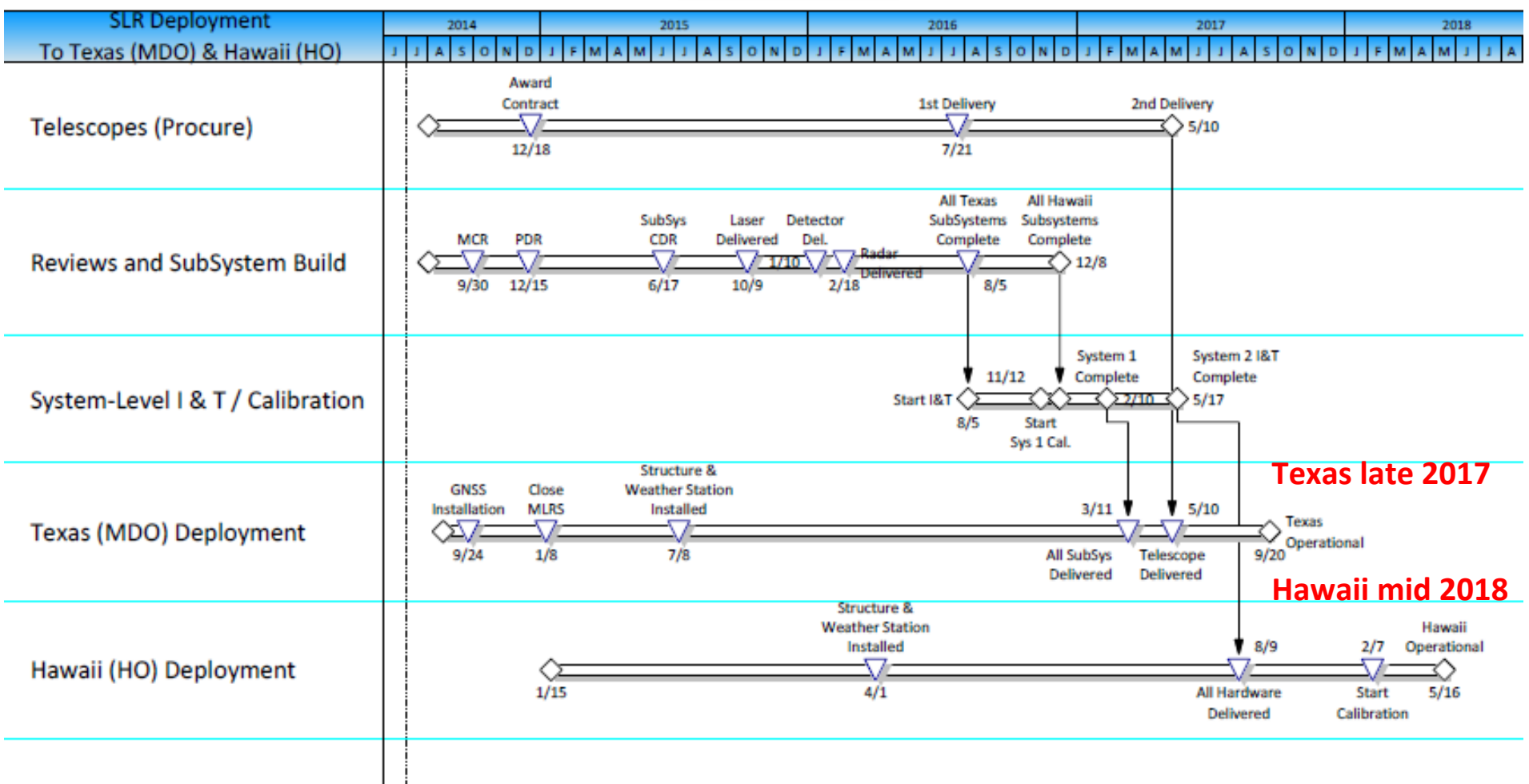

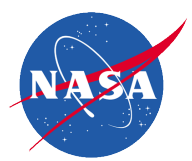

# Summary



- ◆ SGSLR will be the SLR part of NASA's Next Generation Space Geodesy Network.
- ◆ These systems will be based upon the NGSLR design but with moderate design changes to make them more robust, easier to maintain, more automated, and with increased performance (stability and precision).
- ◆ The first deployments will be to Texas (near MLRS) and Hawaii (not far from TLRs-4).
- ◆ Future deployments will provide a more evenly distributed global network than currently exists.