

# ILRS SLR MISSION SUPPORT REQUEST FORM (version: January 2018)

## SUBMISSION STATUS:

- New Submission (default)
- Incremental Submission (accepted only for a follow-on mission; fill-in new information only)  
(provide the reference mission and the date approved by the ILRS: \_\_\_\_\_)

## SECTION I: MISSION INFORMATION:

### General Information:

Satellite Name: \_\_\_\_\_  
Satellite Host Organization: \_\_\_\_\_  
Web Address: \_\_\_\_\_

### Contact Information:

#### Primary Technical Contact Information:

Name: \_\_\_\_\_  
Organization and Position: \_\_\_\_\_  
Address: \_\_\_\_\_  
Phone No.: \_\_\_\_\_  
E-mail Address: \_\_\_\_\_

#### Alternate Technical Contact Information:

Name: \_\_\_\_\_  
Organization and Position: \_\_\_\_\_  
Address: \_\_\_\_\_  
Phone No.: \_\_\_\_\_  
E-mail Address: \_\_\_\_\_

#### Primary Science Contact Information:

Name: \_\_\_\_\_  
Organization and Position: \_\_\_\_\_

Address: \_\_\_\_\_  
Phone No.: \_\_\_\_\_  
E-mail Address: \_\_\_\_\_

Alternate Science Contact Information:

Name: \_\_\_\_\_  
Organization and Position: \_\_\_\_\_  
Address: \_\_\_\_\_  
Phone No.: \_\_\_\_\_  
E-mail Address: \_\_\_\_\_

**Mission Specifics:**

Scientific or Engineering Objectives of Mission:  
(specify)

Role of Satellite Laser Ranging (SLR) for the Mission:  
(specify)

Anticipated Launch Date: \_\_\_\_\_  
Expected Mission Duration: \_\_\_\_\_  
Required Orbital Accuracy: \_\_\_\_\_

**Anticipated Orbital Parameters:**

Altitude (Min & Max for eccentric orbits): \_\_\_\_\_ km

Inclination: \_\_\_\_\_ degrees  
Eccentricity: \_\_\_\_\_  
Orbital Period: \_\_\_\_\_  
Frequency of Orbital Maneuvers: \_\_\_\_\_

**Mission Timeline:**

(example)

Should include when SLR is to start within the mission timeline, such as "on insertion into orbit" or "launch +N" days.

**Tracking Requirements:**

Tracking Schedule:      horizon-to-horizon      custom (specify: \_\_\_\_\_)  
Spatial Coverage:      global ILRS network      custom (specify: \_\_\_\_\_)  
Temporal Coverage:      full-time      custom (specify: \_\_\_\_\_)  
Normal Point Bin Size (Time Span): \_\_\_\_\_ seconds

(Choose one from 5, 15, 30, 120 and 300 seconds. Justify if other bin size is required.)

(See the "Bin Size" of other satellites on the ILRS Web site at

[http://ilrs.gsfc.nasa.gov/missions/satellite\\_missions/current\\_missions/index.html](http://ilrs.gsfc.nasa.gov/missions/satellite_missions/current_missions/index.html).)

Prediction Center: \_\_\_\_\_

**Prediction Technical Contact Information:**

Name: \_\_\_\_\_

Organization and Position: \_\_\_\_\_

Address: \_\_\_\_\_

Phone No.: \_\_\_\_\_

E-mail Address: \_\_\_\_\_

Priority of SLR for POD:      Primary      Secondary      Backup

**Other Sources of POD:**

GNSS     DORIS     Accelerometer     other (specify: \_\_\_\_\_ )

**Other comments on mission information:**

(specify) (list backup prediction centers and references/links to non-SLR techniques if available)

## SECTION II: TRACKING RESTRICTIONS:

Several types of tracking restrictions have been required during some satellite missions. See [http://ilrs.gsfc.nasa.gov/satellite\\_missions/restricted.html](http://ilrs.gsfc.nasa.gov/satellite_missions/restricted.html) for a complete discussion.

- 1) Elevation restrictions: Certain satellites have a risk of possible damage when ranged near the zenith. Therefore a mission may want to set an elevation (in degrees) above which a station may not range to the satellite.
- 2) Go/No-go restrictions: There are situations when on-board detectors on certain satellites are vulnerable to damaged by intense laser irradiation. These situations could include safe hold position or maneuvers. A small ASCII file is kept on a computer controlled by the satellite's mission which includes various information and the literal "go" or "nogo" to indicate whether it is safe to range to the spacecraft. Stations access this file by ftp every 5-15 minutes (as specified by the mission) and do not range when the flag file is set to "nogo" or when the internet connection prevents reading the file.
- 3) Segment restrictions: Certain satellites can allow ranging only during certain parts of the pass as seen from the ground. These missions provide station-dependent files with lists of start and stop times for ranging during each pass.
- 4) Power limits: There are certain missions for which the laser transmit power must always be restricted to prevent detector damage. This requires setting laser power and beam divergence at the ranging station before and after each pass. While the above restrictions are controlled by software, this restriction is often controlled manually.

Many ILRS stations support some or all of these tracking restrictions. You may wish to work through the ILRS with the stations to test their compliance with your restrictions or to encourage additional stations that are critical to your mission to implement them.

The following information gives the ILRS a better idea of the mission's restrictions. Be aware that once predictions are provided to the stations, there is no guarantee that forgotten restrictions can be immediately enforced.

Are there any science instruments, detectors, or other instruments on the spacecraft that can be damaged or confused by excessive radiation, particularly in any one of these wavelengths (532nm, 1064nm, 846nm, or 432nm)?

No            Yes (specify the instrument or  
                 detector in question, providing  
                 the wavelength bands and  
                 modes of sensitivity.)

Are there times when the LRA (Laser Retroreflector Array) will not be accessible from the ground?

No            Yes (specify: \_\_\_\_\_)

(If so, go/nogo or segmentation files might be used to avoid ranging an LRA that is not accessible.)

**→ Skip the next questions and go directly to SECTION III if you answered "No" to both of the above questions.**

Is there a need for an elevation tracking restriction?

No Yes (What elevation (minimum to maximum in degrees)? \_\_\_\_\_ degrees )

Is there a need for a go/no-go tracking restriction?

No Yes (Explain the reason(s) \_\_\_\_\_)

Is there a need for a pass segmentation restriction?

No Yes (Explain the reason(s) \_\_\_\_\_)

Is there a need for a laser power restriction?

No

Yes (Under what circumstances? \_\_\_\_\_)

(What is the maximum permitted power level **at** the satellite (nJ/cm<sup>2</sup>)? \_\_\_\_\_)

(Is manual control of laser transmit power acceptable? Yes No)

For ILRS stations to range to satellites with restrictions, the mission sponsor must agree to the following statement:

*“The mission sponsor agrees not to make any claims against the station or station contractors or subcontractors, or their respective employees for any damage arising from these ranging activities, whether such damage is caused by negligence or otherwise, except in the case of willful misconduct.”*

Please provide signature to express agreement to above statement:

Signature: \_\_\_\_\_

Date: \_\_\_\_\_

Name (print): \_\_\_\_\_

Organization and Position: \_\_\_\_\_

**Other comments on tracking restrictions:**

(specify)

**SECTION III: RETROREFLECTOR ARRAY INFORMATION:**

A prerequisite for accurate reduction of laser range observations is a complete set of pre-launch parameters that define the characteristics and location of the LRA on the satellite. The set of parameters should include a general description of the array, including references to any ground-tests that may have been carried out, array manufacturer and whether the array type has been used in previous satellite missions. So the following information is requested:

Retroreflector Primary Contact Information:

Name: \_\_\_\_\_

Organization and Position: \_\_\_\_\_

Address: \_\_\_\_\_  
\_\_\_\_\_

Phone No.: \_\_\_\_\_

E-mail Address: \_\_\_\_\_

Array type:

Single reflector    Spherical    Hemispherical/Pyramid    Planar

other (specify: \_\_\_\_\_ )

Attach a diagram or photograph of the satellite that shows the position of the LRA, at the end of this document.

Attached

Attach a diagram or photograph of the whole LRA at the end of this document.

Attached    Same as above, Not attached (acceptable only for a cannonball satellite)

Array manufacturer:

\_\_\_\_\_

Link (URL and/or reference) to any ground-tests that were carried out on the array:

\_\_\_\_\_  
\_\_\_\_\_

Has the LRA design and/or type of cubes been used previously?

No    Yes (List the mission(s): \_\_\_\_\_)

For accurate orbital analysis it is essential that full information is available in order that the 3-dimensional position of the satellite center of mass may be referred to the location in space at which the laser range measurements are made. To achieve this, the 3-D location of the LRA phase center must be specified in a satellite-body-fixed reference frame with respect to the satellite's mass center. In practice this means that the following parameters must be available at 1 mm accuracy or better.

Define the satellite-body-fixed XYZ coordinates (i.e. origin and axes) on the spacecraft:  
(specify) (add a diagram in the attachment)

Relate the satellite-body-fixed XYZ coordinates to a Celestial/Terrestrial/Solar Reference Frame including the attitude control policy:  
(specify) (add a diagram in the attachment)

The 3-D location of the satellite's mass center in satellite-body-fixed XYZ coordinates is:

Always fixed at (0, 0, 0)

Always fixed at ( \_\_\_\_\_, \_\_\_\_\_, \_\_\_\_\_ ) in mm

Time-varying by approximately ( \_\_\_\_\_ ) mm during the mission lifetime.

Will a time-variable table of the mass center location be available on the web?

No      Yes (URL: \_\_\_\_\_)

The 3-D location (or time-variable range) of the phase center of the LRA in the satellite-body-fixed XYZ coordinates:

( \_\_\_\_\_, \_\_\_\_\_, \_\_\_\_\_ ) in mm

The following information on the corner cubes must also be supplied.

The XYZ coordinates referred to in the following are given in:

Satellite-body-fixed system (same as above)

LRA-fixed system (specify below)

(specify the origin and orientation) (add a diagram in the attachment )



List the position (XYZ) of the center of the front face of each corner cube, and the orientation (two angles or normal vector) and the clocking (horizontal rotation) angle of each corner cube. Note that the angles should be clearly defined.

Attached at the end of this document

Listed here (acceptable for small number (10 or fewer) of corner cubes)  
(specify) (add a diagram in the attachment)

Is the corner cube recessed in its container (i.e. can the container obscure a part of the corner cube)?

No            Yes (specify below)

(specify) (add a diagram)

The size of each corner cube: Diameter (\_\_\_\_\_) mm    Height (\_\_\_\_\_) mm

The material from which the cubes are manufactured (e.g. quartz):

---

The refractive index of the cube material

= \_\_\_\_\_ for wavelength  $\lambda = 0.532$  micron

= \_\_\_\_\_ as a function of wavelength  $\lambda$  (micron):

The group refractive index of the cube material, as a function of wavelength  $\lambda$  (micron):

= \_\_\_\_\_ for wavelength  $\lambda = 0.532$  micron

= \_\_\_\_\_ as a function of wavelength  $\lambda$  (micron):

Dihedral angle offset(s) and manufacturing tolerance (in arcseconds):

---

Radius of curvature of front surfaces of cubes:

Not applied      Yes (specify: \_\_\_\_\_)

Flatness of cubes' surfaces:

---

Back-face coating:

Uncoated      Coated (specify the material: \_\_\_\_\_)

**Other comments on LRA:**

(specify) (add a reference to a study of the optical response simulation/measurement if available) (add a diagram if applicable)

## SECTION IV: MISSION CONCURRENCE

The ILRS is a voluntary organization that operates under the auspices of the International Association of Geodesy (IAG). The ILRS adheres to the IAG policy to make all acquired laser ranging data and derived products publicly available. We request that the mission website, as well as mission publications, reference the scientific work derived from ILRS data and derived products, **acknowledge** the role of the ILRS. This acknowledgment is crucial for the continued support from the funding agencies of the ILRS participating organizations.

As an authorized representative of the \_\_\_\_\_ mission, I hereby request and authorize the ILRS to track the satellite described in this document.

Name (print): \_\_\_\_\_

Organization and Position: \_\_\_\_\_

Signature: \_\_\_\_\_

Date: \_\_\_\_\_

Send form to: ILRS Central Bureau  
c/o Carey Noll  
NASA GSFC  
Code 61A  
Greenbelt, MD 20771  
USA  
301-614-6542 (Voice)  
301-614-6015 (Fax)  
Carey.Noll@nasa.gov

**SECTION V: ATTACHMENT(S)**

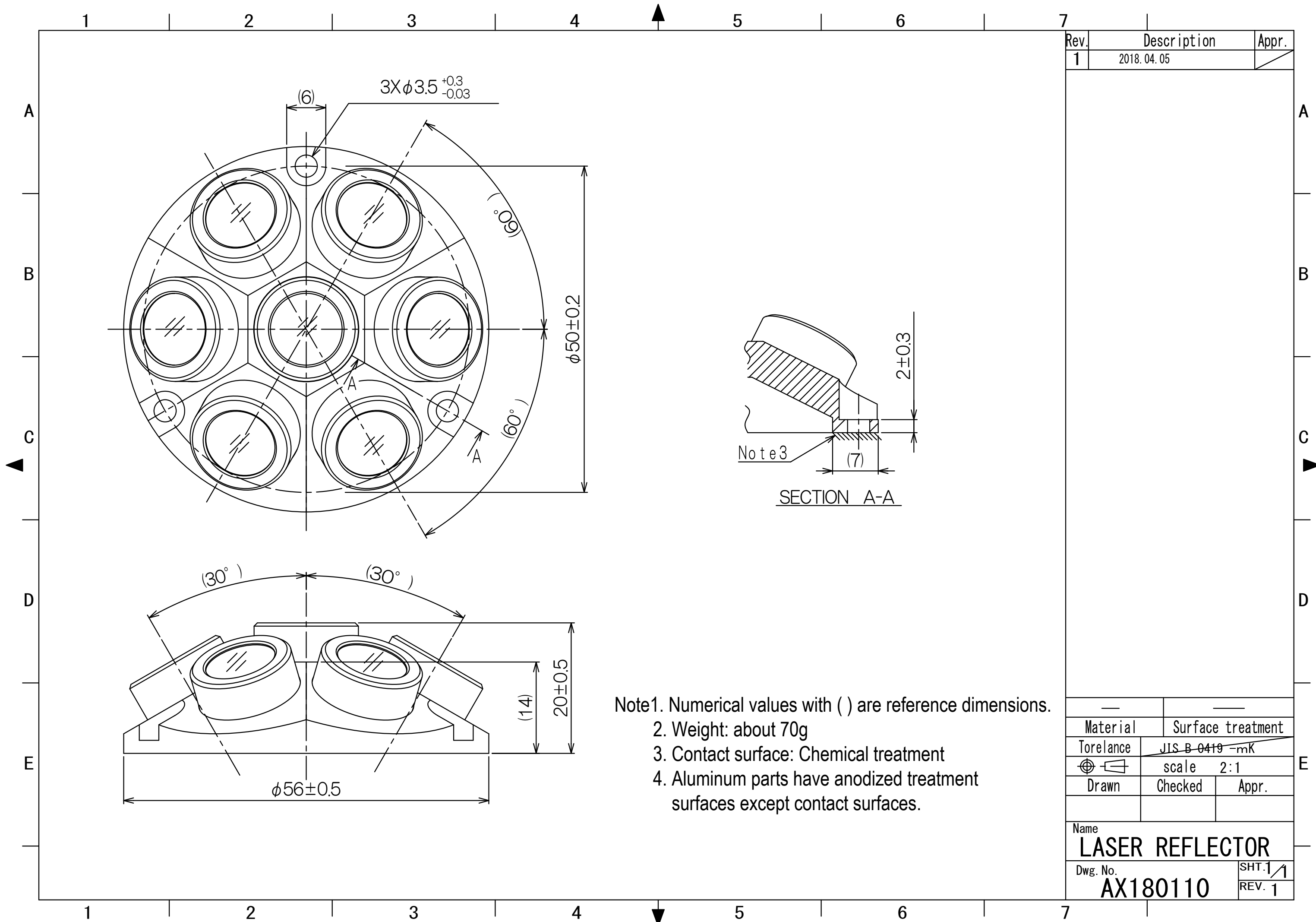

Rev.	Description	Appr.
1	2018.04.05	

- Note1. Numerical values with ( ) are reference dimensions.  
 2. Weight: about 70g  
 3. Contact surface: Chemical treatment  
 4. Aluminum parts have anodized treatment surfaces except contact surfaces.

Material		Surface treatment	
Tolerance		JIS-B-0419 -mK	
		scale 2:1	
Drawn	Checked	Appr.	
Name <b>LASER REFLECTOR</b>			
Dwg. No. <b>AX180110</b>		SHT. 1 / 1 REV. 1	

Fig.2 MICD of laser reflector

NOTES:

1. SUBSTRATE : FUSED SILICA
2. BLACK OVERPAINT IS 30-60  $\mu\text{m}$  THICK
3. COATING (APPLY ACROSS COATING APERTURE)  
 S1: PROTECTED ALUMINUM  
 $R(\text{avg}) > 85\%$  @ 400 - 700nm W/BLACK OVERPAINT  
 $0.3 \text{ J/cm}^2$  @ 532nm & 1064nm, 10ns
- S2: UNCOATED
4. FINE GRIND SURFACE
5. ROHS COMPLIANT

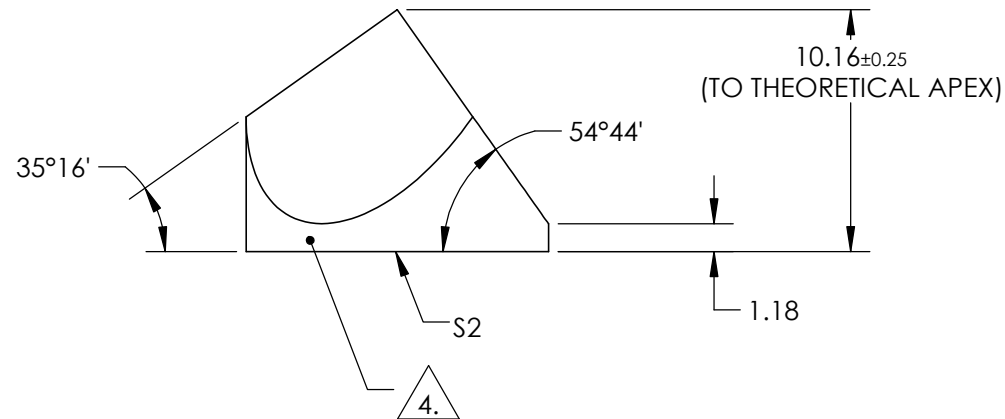
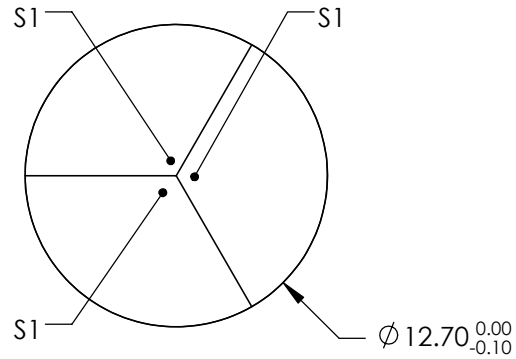
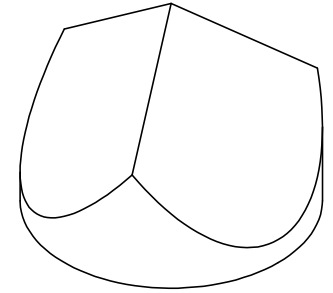

**FOR INFORMATION ONLY:  
DO NOT MANUFACTURE  
PARTS TO THIS DRAWING**

SPECIFICATIONS SUBJECT TO CHANGE WITHOUT NOTICE  
DIMENSIONS ARE FOR REFERENCE ONLY

REV A	S1 & S2
SURFACE FLATNESS	$\lambda/10$
SURFACE QUALITY	20-10
WAVELENGTH RANGE	400 - 700 nm
ANGLE TOL. (arcsec)	5
BEVEL	PROTECTED AS NEEDED

THIRD ANGLE PROJECTION	
ALL DIMS IN	mm

Edmund Optics®	
TITLE	12.7mm ALUMINUM COATED, FUSED SILICA CORNER CUBE
DWG NO	49013
SHEET 1 OF 1	

12.7mm Aluminum Coated, Fused Silica Corner Cube (Edmund Opt.)	
Stock #49-013	
Diameter (mm):	12.70 +0.00/-0.10
Height (mm):	10.16 + 30-60µm w/Black Overpaint
Coating:	Protected Aluminum (400-2000nm)
Beam Deviation (arcsec):	5
Coating Specification:	Entrance: Uncoated Reflective Surfaces: Ravg >85% @ 400 - 700nm w/Black Overpaint
Height Tolerance (mm):	±0.25
Image Orientation:	Left-Handed
Note:	Black Overpaint is 30-60 µm Thick
Image Orientation:	Left-Handed
Note:	Black Overpaint is 30-60 µm Thick
Ray Deviation (°):	180
Substrate:	Fused Silica
Surface Flatness:	λ/10
Surface Quality:	20 - 10
Type:	Retroreflector
Typical Energy Density Limit:	Reflective Surfaces: 0.3 J/cm <sup>2</sup> @ 532nm & 1064nm, 10ns
Wavelength Range (nm):	400 - 700
RoHS:	Compliant

# Location of Laser Retroreflectors on ELSA-d Chaser

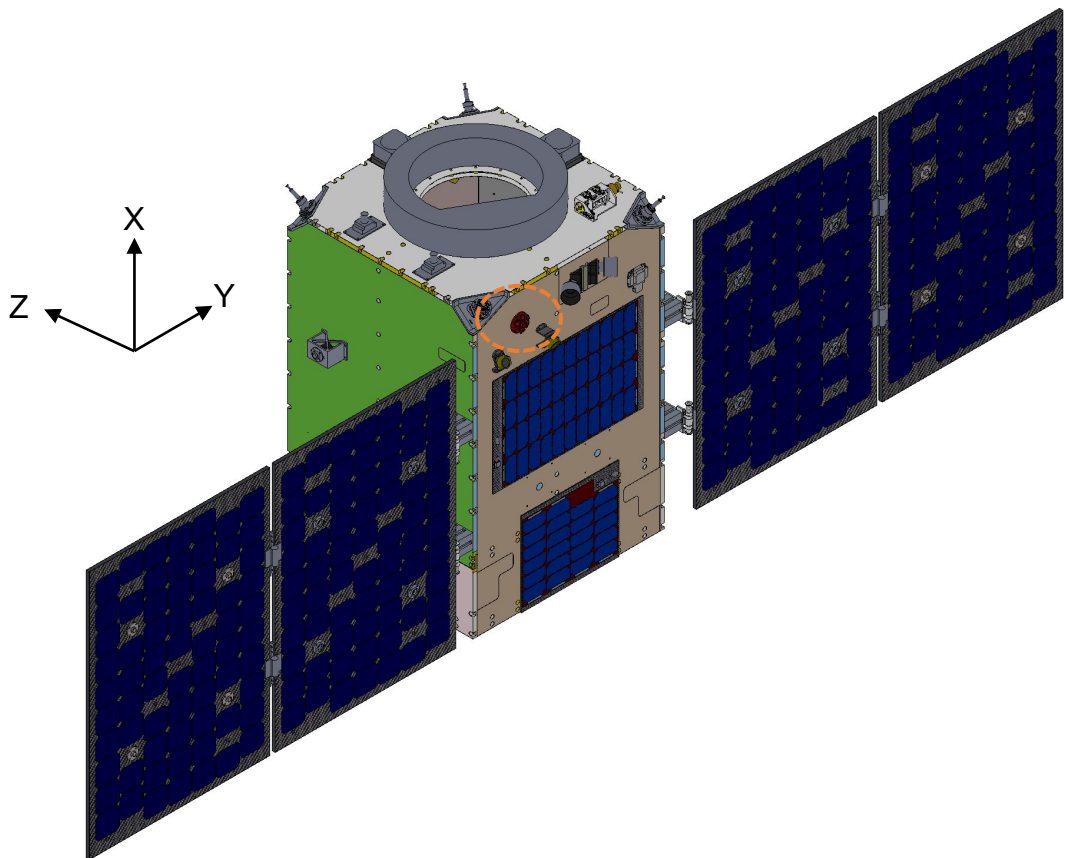
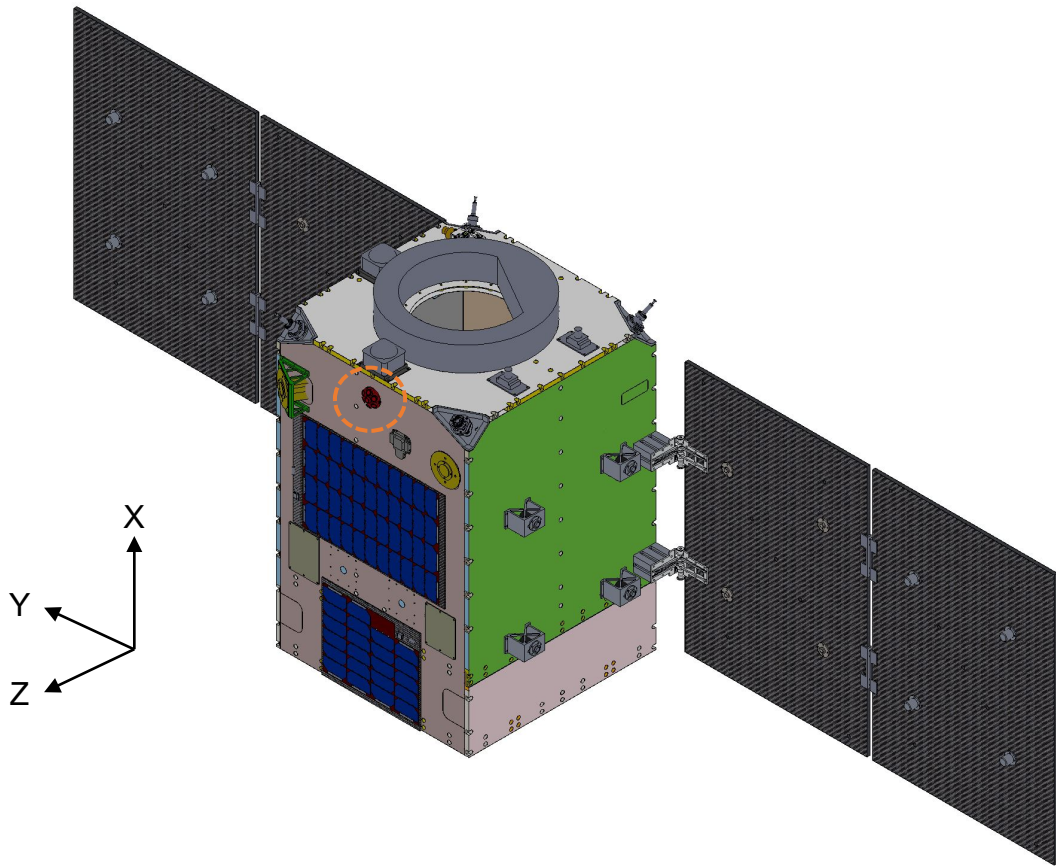



List the position (XYZ) of the center of the front face of each corner cube, and the orientation (two angles or normal vector) and the clocking (horizontal rotation) angle of each corner cube. Note that the angles should be clearly defined.

#### Array 1 (phase centre [945.00, 0.00, 320.20])

```
cca1_ca1: position = [945.    0.  340.2] mm, normal vector = [0 0 1]
cca1_ca2: position = [964.4  11.2 334.2] mm, normal vector = [0.433 0.25  0.866]
cca1_ca3: position = [945.    22.4 334.2] mm, normal vector = [0.    0.5  0.866]
cca1_ca4: position = [925.6  11.2 334.2] mm, normal vector = [-0.433 0.25  0.866]
cca1_ca5: position = [925.6 -11.2 334.2] mm, normal vector = [-0.433 -0.25  0.866]
cca1_ca6: position = [945.   -22.4 334.2] mm, normal vector = [-0.   -0.5  0.866]
cca1_ca7: position = [964.4 -11.2 334.2] mm, normal vector = [ 0.433 -0.25  0.866]
```

#### Array 2 (phase centre [910.00, -172.00, -320.20])

```
cca2_ca1: position = [ 910.  -172.  -340.2] mm, normal vector = [ 0  0 -1]
cca2_ca2: position = [ 929.4 -166.  -329. ] mm, normal vector = [ 0.433 -0.866  0.25 ]
cca2_ca3: position = [ 910.  -166.  -317.8] mm, normal vector = [ 0.   -0.866  0.5  ]
cca2_ca4: position = [ 890.6 -166.  -329. ] mm, normal vector = [-0.433 -0.866  0.25 ]
cca2_ca5: position = [ 890.6 -166.  -351.4] mm, normal vector = [-0.433 -0.866 -0.25 ]
cca2_ca6: position = [ 910.  -166.  -362.6] mm, normal vector = [-0.   -0.866 -0.5  ]
cca2_ca7: position = [ 929.4 -166.  -351.4] mm, normal vector = [ 0.433 -0.866 -0.25 ]
```